

TENIO

1. About this installation instructions

The TENIO fiber enclosure is a modular enclosure that is composed of different building blocks to meet the specific client needs. This installation instruction provides an overview of the building blocks and their variants and how they fit together.

Environmental conditions in which the enclosure can be used are described in this document as well as product dimensions and capacity (splice capacity, cable diameter range, and cable types).

In addition this instruction will explain:

- how to prepare the enclosure, feeder cable, and drop cables;
- how to install cables in the enclosure (including use of the CTU);
- how to route fibers to the splice and/or patch trays or to the POC storage area;
- how to install fibers on the trays;
- how to close and properly seal the enclosure;
- how to mount the enclosure with the mounting bracket; and
- how to use the external cable fixation bracket.

This instruction also includes a section describing re-entry to the enclosure after installation for adding a new cable or for accessing the fiber management system.

2. Warnings and caution

2.1. Fiber optic cables may be damaged if bent or curved to a radius that is less than the recommended minimum bend radius. Always observe the recommended bend radius limit when installing fiber optic cables and patch cords.

2.2. Exposure to laser radiation can seriously damage the retina of the eye. Do not look into the ends of any optical fiber. Do not assume the laser power is turned off or that the fiber is disconnected at the other end.

3. List of acronyms and abbreviations

POC	Passive Optical Components
CTU	Cable Termination Unit
SKG	Sealing Kit Gel
SLE	SLim Element (tray)
FAS	Fiber Arrangement System

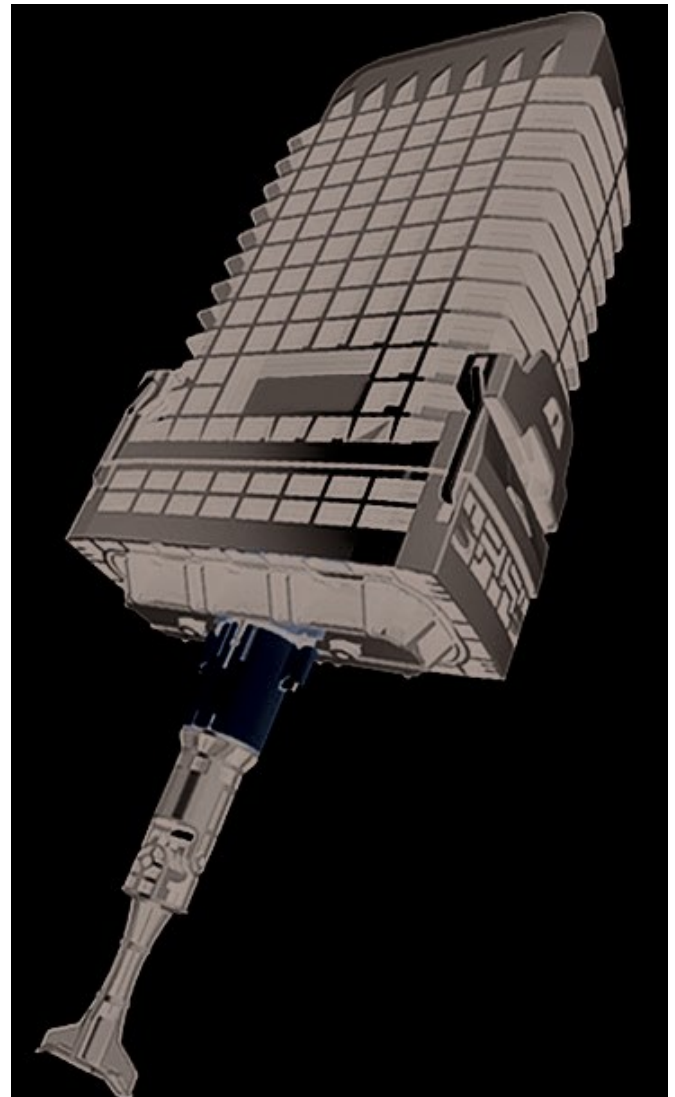

Contents

1.	About this installation instruction.....	1	9.3.	Install CTU on cable	9
2.	Warnings and caution	1	9.3.1.	CTU-L - central strength member.....	9
3.	List of acronyms and abbreviations	1	9.3.2.	CTU-L - dual strength member	11
4.	General product description	2	9.3.3.	CTU-L - aramid yarn.....	11
4.1.	Sizes and dimensions	2	9.3.4.	CTU-S - aramid yarn.....	12
4.2.	Overview of the functionalities (building blocks) of the enclosure	3	10.	Install gel seal segments.....	13
4.2.1.	Towers.....	4	10.1.	Install side seal segments	13
4.2.2.	Trays.....	4	10.2.	Install SKG for CTU-L.....	14
4.2.3.	FAS.....	4	10.3.	Install SKG for CTU-S	14
4.2.4.	Passive optical components storage	4	10.4.	Install dummy SKG.....	15
4.2.5.	Tube/subunit holder.....	4	11.	Install looped feeder cable.....	15
4.2.6.	CTU holder area.....	4	11.1.	Secure cable to enclosure	15
4.2.7.	Cable seal	4	11.2.	Store loop.....	16
4.2.8.	Loop storage area.....	4	11.3.	Tube/subunit holder.....	16
4.2.9.	Fiber guidance pin and wedge	4	12.	Install drop cable	18
5.	Kit content.....	5	13.	Splice application	19
5.1.	Principle parts.....	5	13.1.	Routing to tray	19
5.2.	Customized parts	5	13.2.	Routing on tray.....	20
5.2.1.	Cable seal (SKG).....	5	14.	Patch application.....	20
5.2.2.	Trays.....	6	15.	Close and seal enclosure.....	21
5.2.3.	CTU's.....	6	16.	External cable fixation	22
6.	Accessories	6	17.	Mounting bracket.....	23
6.1.	Mounting bracket.....	6	17.1.	Dimensions.....	23
6.2.	External cable fixation.....	6	17.2.	Mount the enclosure	23
7.	Tools required	6	17.2.1.	Wall mounting	23
8.	Prepare organizer	7	17.2.2.	Pole mounting.....	24
8.1.	Open enclosure	7	17.2.3.	Mount enclosure on the bracket	24
8.2.	Install splice trays.....	8	17.3.	Open enclosure when using the bracket.....	24
8.3.	Install patch tray.....	8	17.3.1.	Remove dome only	24
8.4.	Fiber guidance pin and wedge	8	17.3.2.	Remove dome and base	24
8.5.	Install POC (Passive Optical Components).....	8	18.	Re-entry.....	25
9.	Prepare cable	9	19.	Trade-marks	25
9.1.	Loop cable	9	20.	Contact information.....	25
9.2.	Drop cable (stub cable).....	9			

4. General product description

This enclosure is deployed in the distribution and drop part of the spliced fiber network. It is designed to allow reconfiguration in the field, meaning the enclosure can be re-entered to add new cables as required.

Environmental conditions

The enclosure is designed to meet **20kPa and 2 m water head** sealing performance compliant with prEN50411-2-10. It is suitable for underground (manhole, handhole), ground level (pedestal) and aerial use.

The TENIO fiber enclosure is a modular butt splice enclosure fully compatible with **G.652.D SM fiber**. Fiber and cable technology independent, it can be configured to meet specific requirements in terms of maximum splices, loop storage, optical device storage, and cable diameter.

Two sizes are available, B6 and C6/C6H, to allow this flexibility (see dimensions on the next page).

Maximum capacity of splices/trays

Trays are designed to hold SMOUV or ANT splice protectors depending on the type. A FAS is used in all splice trays. The design of the tray provides bend control and makes sure the fiber cannot make bends smaller than radius 40 mm (1.57"). Minimum over length storage per splice side on the tray is 1.2m (47").

Tenio-B6 can accommodate up to 12 fiber splice trays (type S12 or A12). Each tray houses 12 fiber splices, for a capacity of maximum **144 fiber** splices per closure.

Tenio-C6 can accommodate up to 8 fiber splice trays (type S24 or A24). Each tray houses 24 fiber splices for a capacity of maximum **192 fiber** splices per closure.

Tenio-C6H can accommodate up to 12 fiber splice trays (type SLE). Each tray houses 24 fiber splices for a capacity of maximum **288 fiber** splices per closure.

More information about tray types can be retrieved in installation instruction TC-1320-IP-A, and on the eCatalog.

Cable diameter range

The cable diameter of the TENIO ranges from **2-16mm (0.08-0.63")**.

Depending the required cable range, the enclosure can be composed of various combinations of dedicated cable seal segments. The TENIO can hold in total 6 seal segments. Each seal segment (9 variants in total) is adapted to a specific cable range. For an overview, refer to the eCatalog. These gel seals are put under pressure after installation by engaging the seal mechanism. The seal mechanism exists of 2 latches to seal the dome on the base and a tightening system engaged with the trigger to seal the cables.

Cable type

The TENIO is cable technology independent and can be used with various cable constructions for both feeder cable and drop cable, including microsheat, dual strength member, central core, and loose buffer tube/subunit constructions.

4.1. Sizes and dimensions

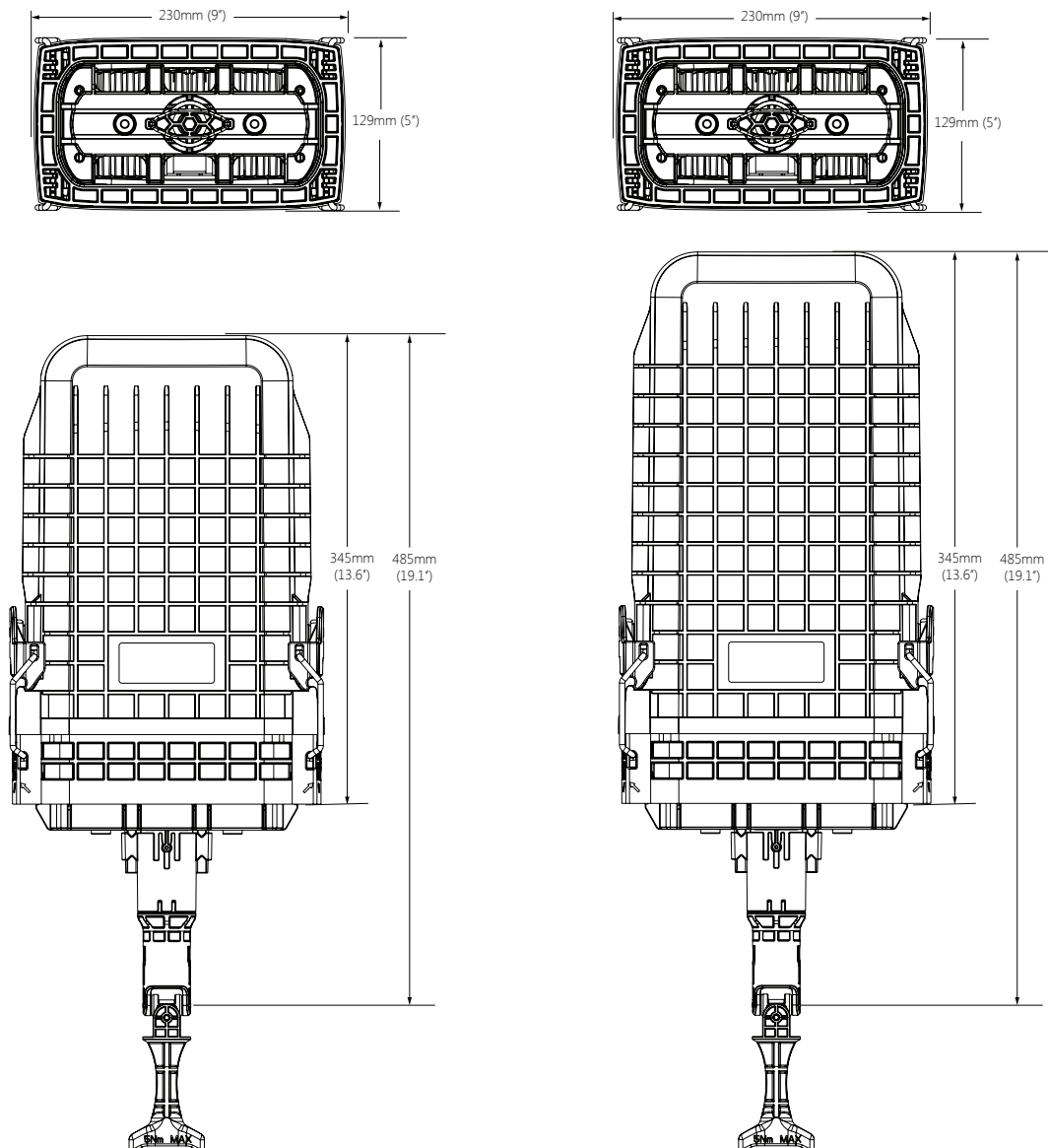

4.2. Overview of the functionalities (building blocks) of the enclosure

When the dome and base are removed (as described in chapter 8), the organizer of the enclosure becomes accessible. Drawings below illustrate the different functionalities (front side and back side) of the 2 sizes.

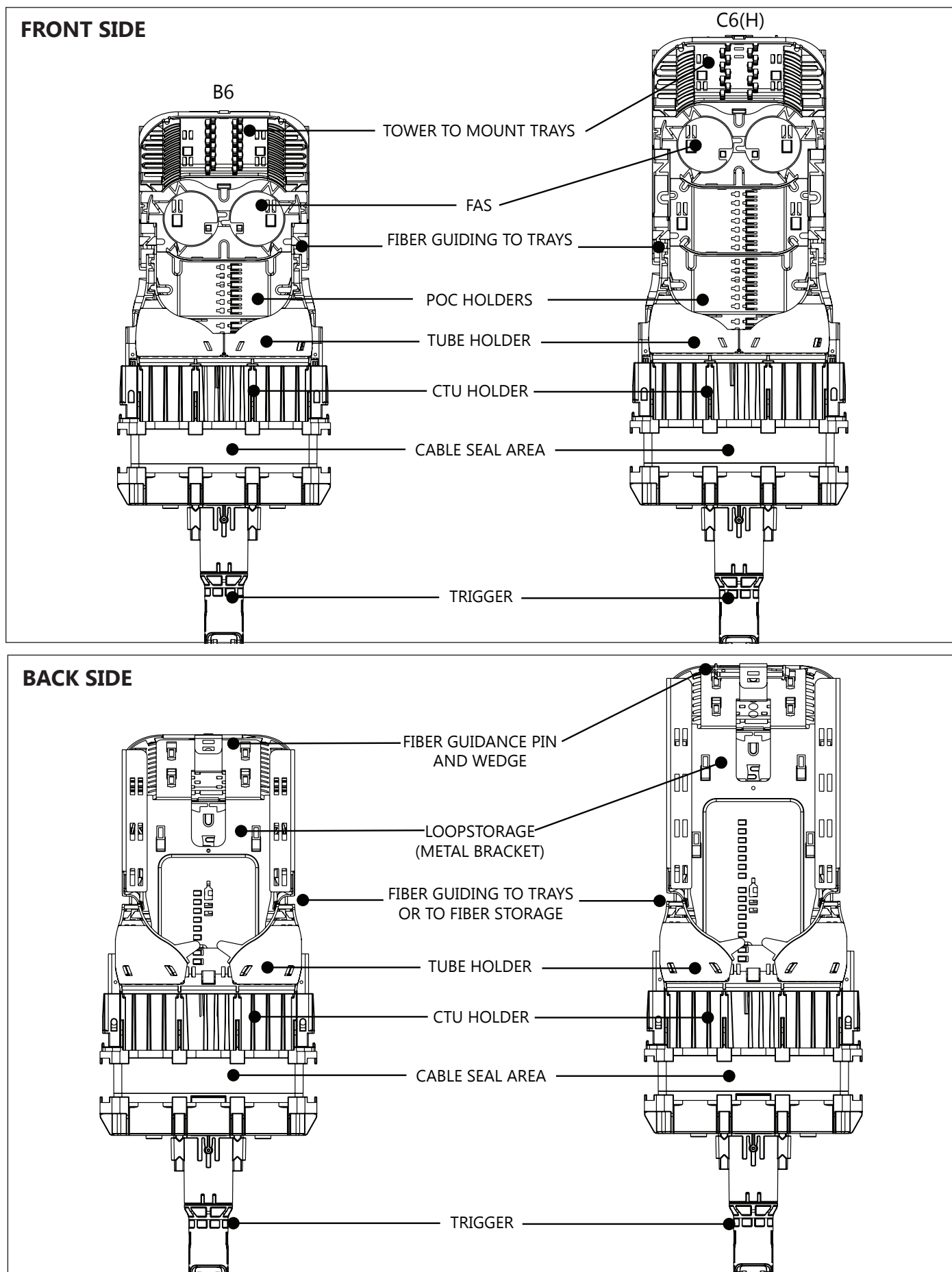

4.2.1. Towers

The towers contain the snap features to hold the trays. There are two towers available, with a different pitch between the trays. The tower mounted on the B6/C6H size has a pitch of 4mm. The tower mounted on a C6 size has a pitch of 6mm.

4.2.2. Trays

Trays should be mounted on the tower in the field. They are either part of the kit content or can be ordered separately. See the eCatalog for more information about the different types.

Splice trays as well as **patch trays** are available to use in the TENIO. Splice trays are designed to hold SMOUV or ANT splice protectors depending the type. A FAS is used in all splice trays, providing an R40 bend radius. Minimum over length storage per splice side on the tray is 1.2m (47").

4.2.3. FAS (Fiber Arrangement System)

The two drums in the FAS area are used to redirect the fiber routing. Fibers can change direction by making an S-shape over the drums. The area is also used to allow inter tray jumps: fibers routed from one tray to the other need to pass the FAS. Also on the trays a FAS is used to redirect the routing of the fiber.

4.2.4. Passive optical components storage

Depending the application, fiber storage (for example dark fiber) can be stored in this area as well as passive optical components (POC). A dove tail interface cut out is used to install the POC's in this area. The C6 size enclosure can accommodate more POC's than the B6 size. Field installable splitter sub-assemblies with Fused biconoc Taper (FBT) or PLC splitters are available. See eCatalog for more details. The fiber guidance channels bring the fibers to the trays, the FAS or to the POC storage area.

4.2.5. Tube/subunit holder

Tube/subunit holders are present on the front side as well as on the back side of the organizer. In the tube/subunit holder area, the jacket is removed from the tubes/subunits. **Only 250µm fiber continue from this point.** The area is designed to control tube/subunit grow in/ grow out up to 20 mm. The tube/subunit is pushed in one of the channels and the fiber is routed to fiber guidance channels left or right. The fiber can also be guided from the back side of the organizer to the front side to access the trays. To keep the tube/subunits in place, a piece of orange tubing is cut to length and pushed on top of the tube/subunit. A pre-installed transparent protection lid covers the tube/subunit holder.

4.2.6. CTU holder area

In the CTU (Cable Termination Unit) holder area, the black CTU holders are installed. The black CTU holders are available in the SKG's (sealing kit gel). There are 2 models, one model for small CTU's (CTU-S) used with cables with a diameter up until 6 mm (0.24"), and one for large CTU's (CTU-L) used with cables with a diameter up to 16mm (0.63")



Large CTU (CTU-L) can terminate strength members (rods up to Ø 4mm (0.16") and aramid yarn). In one CTU holder 2 or 3 of these CTU's can be installed. Cable diameter range from 5-16 mm (0.20-0.63") and flat cable.

Small CTU (CTU-S) can terminate aramid yarn. 4 or 5 of these CTU's can be installed in one CTU holder. Cable diameter is up to 6 mm (0.24").



4.2.7. Cable seal

The enclosure is sealed with in total 8 gel seal segments. Two of the seal segments are the side seal segments and do not hold a cable.

The other 6 segments can vary depending on the amount of cables and diameter of cables required. For an overview, refer to the eCatalog.

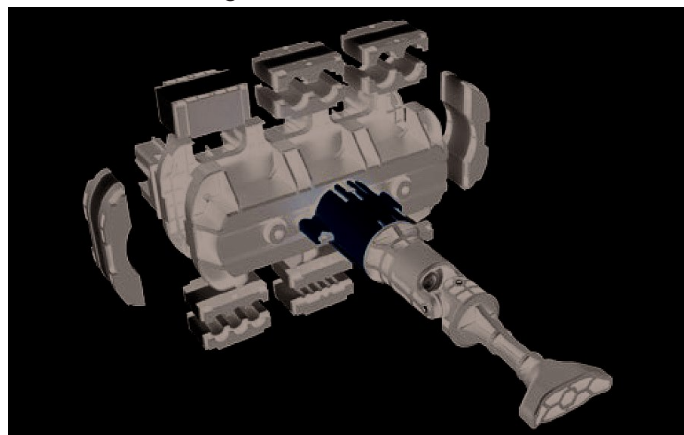

The gels seals are available in the SKG's (sealing kit gel).

4.2.8. Loop storage area

Unused looped tube/subunits can be stored between the metal brackets at the back side of the organizer. If the unused loops of the feeder cable should be stored, the feeder cable should be installed in the middle gel seal segment at the back side of the enclosure.

4.2.9. Fiber dressing tool and wedge

A fiber dressing tool to guide the fibers under the hooks and lips of the tray and the channels, is stored at the backside of the organizer. It is advised to store the fiber dressing tool again in its holder after installation.

A wedge to support the trays is only available in the C6 enclosure in combination with the A24/S24 tray. The purpose of it is to prevent the tray from falling down when hinged open to work on the tray below.

5. Kit content

5.1. Principle parts

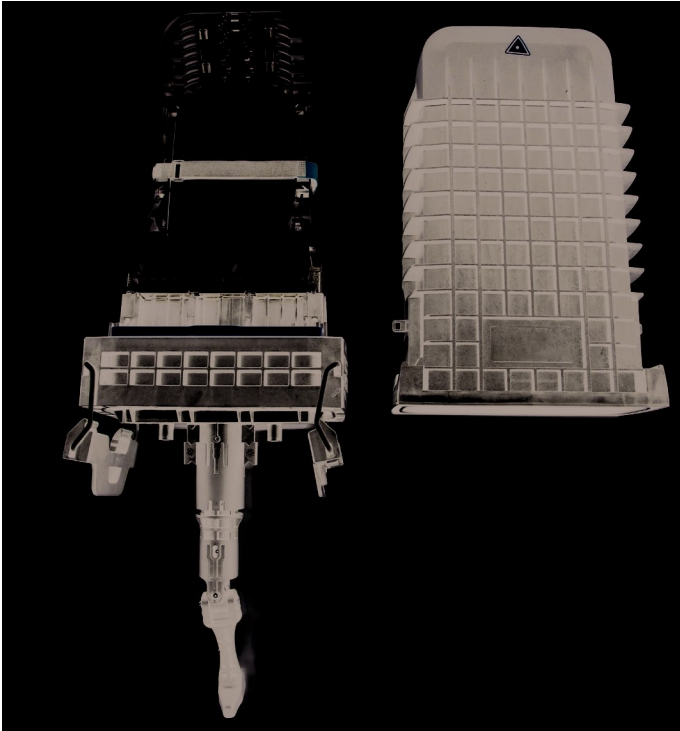

5.1.1 Enclosure with dome and base (picture for reference only, example of a C6).



5.1.2 Orange tubing and the 2 side seal segments.

5.2. Customized parts

5.2.1. Cable seal (SKG)

3 types of SKG's are available: one for the small CTU's, one for the large CTU's and dummies. Following pictures show the kit content of a SKG in the 3 different cases:

SKG for small CTU's:

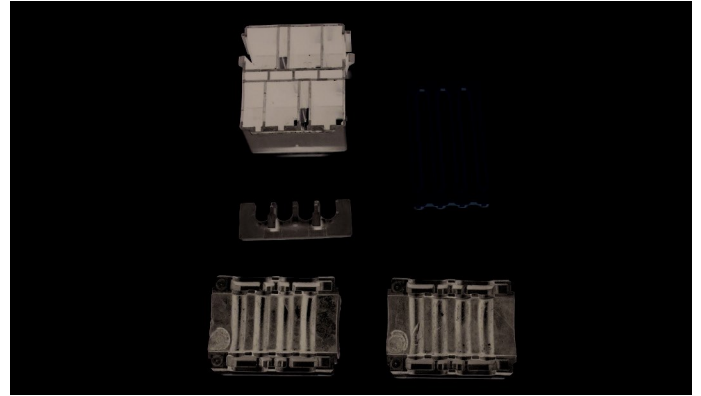

(Picture for reference only)

	Description
1	CTU holder
2	Yellow dummy plugs
3	Cable guide
4	Gel seal segments (2 pcs)

SKG for large CTU:

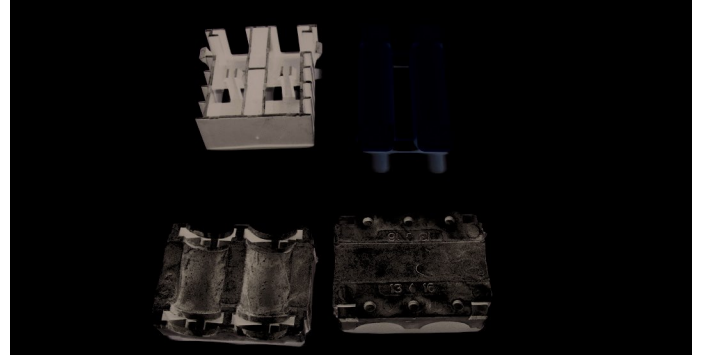

(Picture for reference only)

	Description
1	CTU holder
2	Yellow dummy plugs
3	Gel seal segments (2 pcs)

Dummy seal:



This kit can contain 1 or 2 gel seal segments.

5.2.2. Trays

Quantity and type of tray can differ.
See eCatalog for different options.

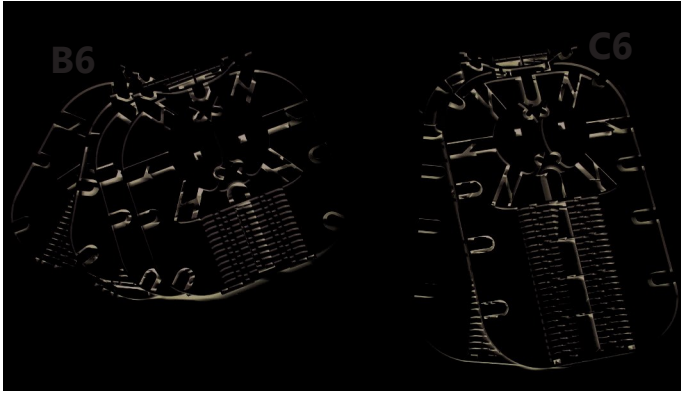

(Picture for reference only)

5.2.3. CTU's

Quantity and type of CTU can differ.

CTU-L

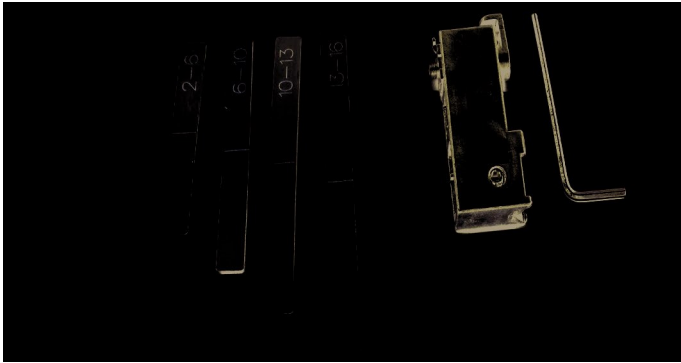

(Picture for reference only)

	Description
1	Metal bands of different lengths
2	CTU
3	Allen key

CTU-S

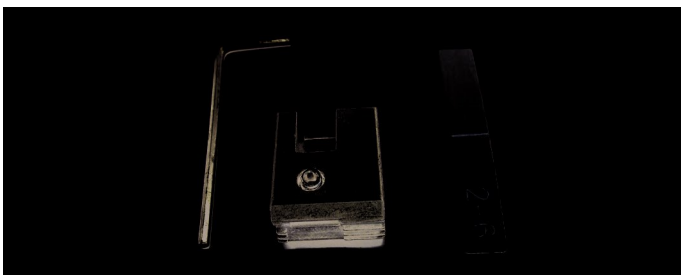

(Picture for reference only)

	Description
1	Metal band
2	CTU
3	Allen key

6. Accessories

6.1. Mounting bracket

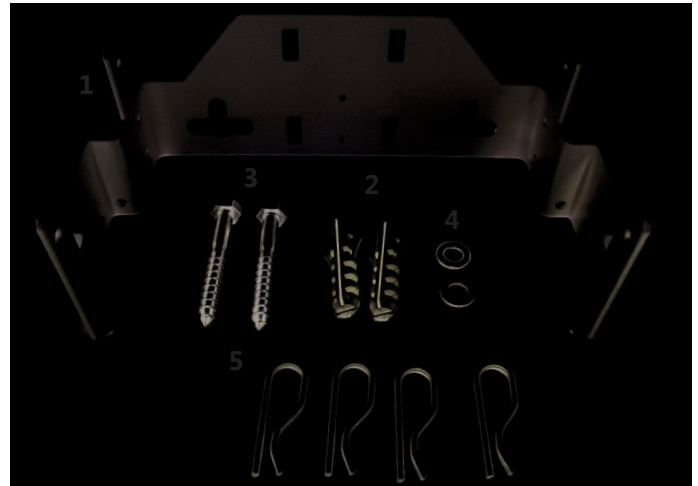

	Description
1	Mounting bracket
2	Plugs
3	Screws (M8-hexagon head)
4	Washers
5	Split pins

6.2. External cable fixation



	Description
1	External cable fixation bracket
2	Foam tape
3	Cable ties
4	Screws (Phillips head)

7. Tools required

Scissors
Measuring tape

Stripping tools,
Cleaning tissues

to cut orange tubing
to measure correct length of
orange tubing and aramid yarn
to prepare cable and fibers
to clean cable and fibers

8. Prepare organizer

Unpack and conduct an inventory of the kits.

8.1. Open enclosure



8.1.1 Lift the latches open and remove the dome.

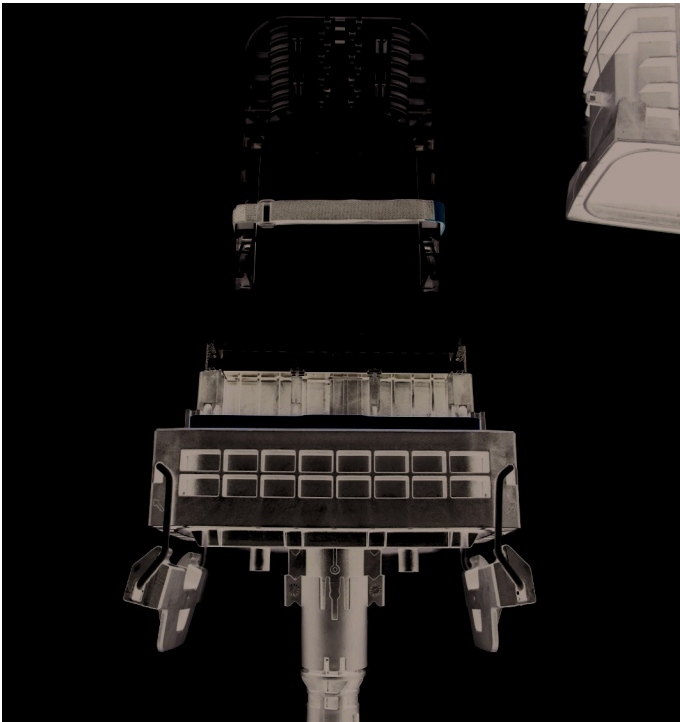

8.1.2 When the dome is removed, the cable management system becomes accessible. When no cables are to be added, base can remain.



8.1.3 If cables are to be added, also the base should be removed. To remove the base, lift the yellow bracket that locks the base to the enclosure. The gel seal area will become accessible.

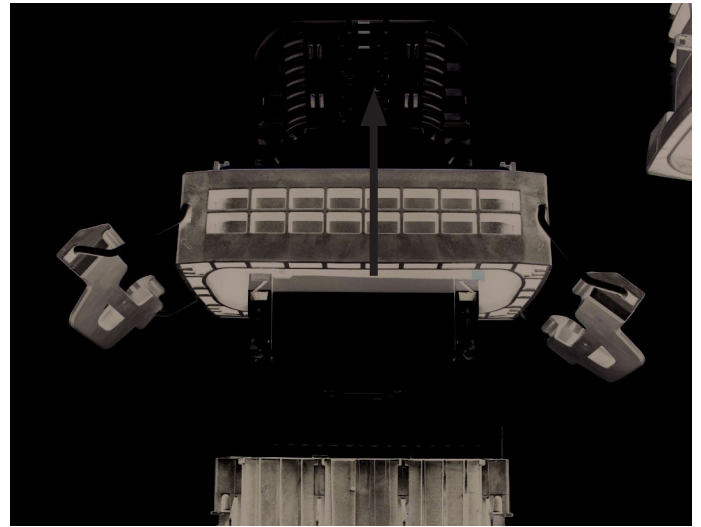

8.1.4 Slide the base over the organizer.



8.1.5 End result of dome and base removed.

8.2. Install splice trays

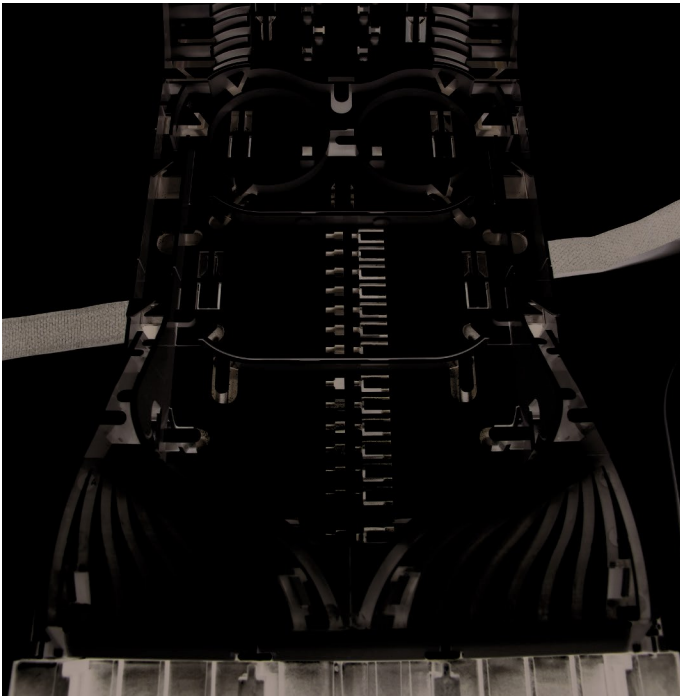

8.2.1 If present, remove loop and hook fastener and tray lid.

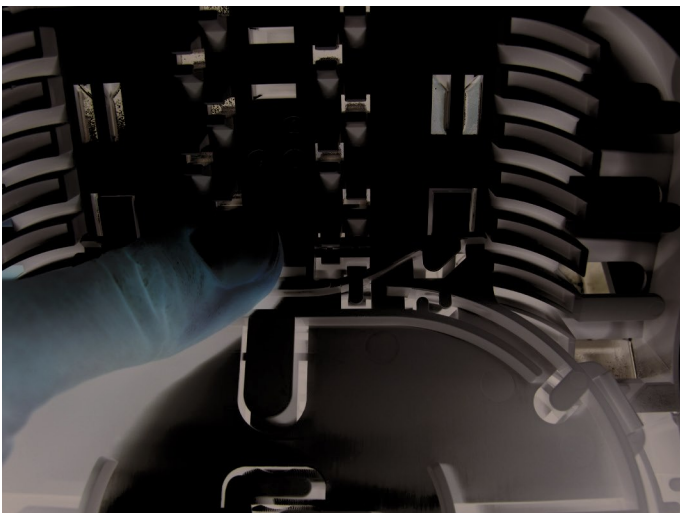

8.2.2 Push the tray hinge into the snap features on the tower. Start with the bottom position.

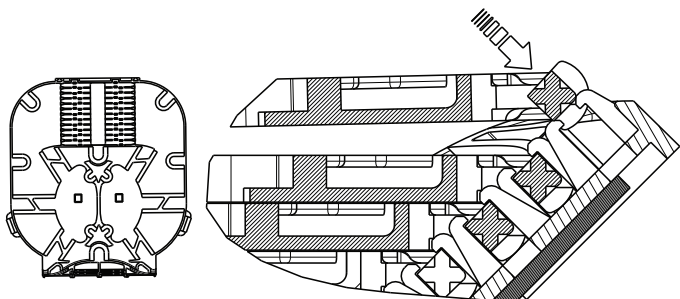

8.2.3 Technical detail of the hinge snapping in the snap features on the tower.

8.3. Install patch tray

If present, the two or three splice trays should be installed in the bottom positions first. On top of these trays, the patch trays are installed. See chapter 14 for more details of the patch application.

8.4. Fiber dressing tool and wedge

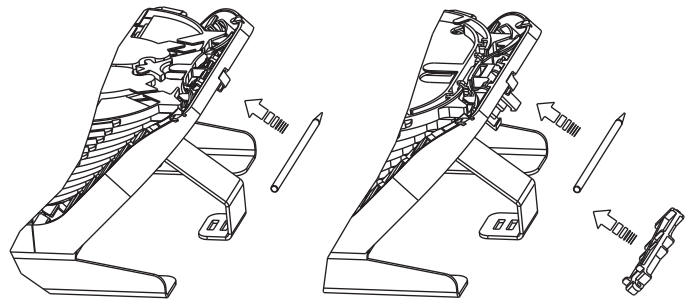

8.4.1 Fiber dressing tool and wedge (applicable with C6 enclosure only), can be retrieved on the backside of the cable management system.

8.4.2 The wedge is used in combination with the A24/S24 tray. The purpose of it is to prevent the tray from falling down when hinged open to work on the tray below.

8.5. Install POC (Passive Optical Components)

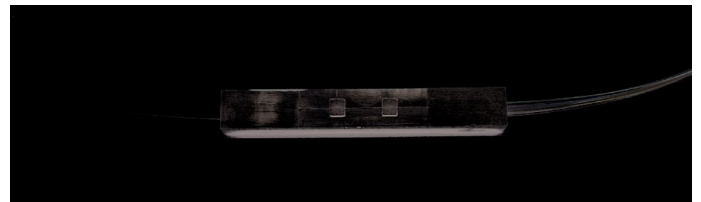

8.5.1 Passive Optical Components holds dove tail features to be able to install it in the POC holder area.

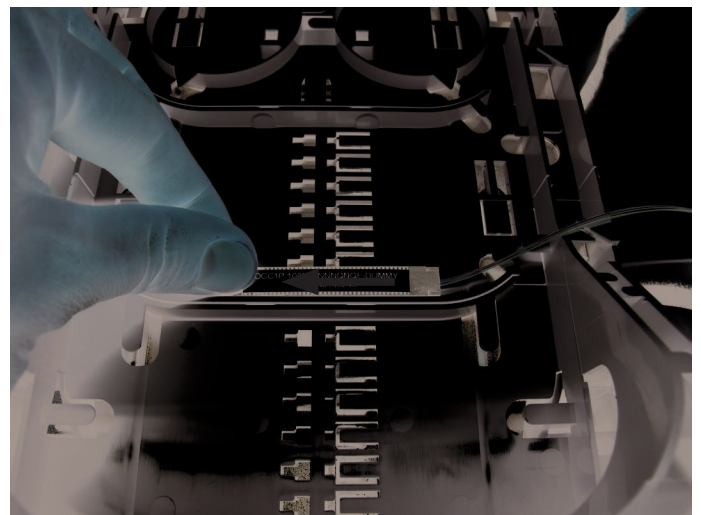

8.5.2 Position the dove tail features in the slots of the POC holder and move the POC to the left side.

9. Prepare cable

9.1. Loop cable



Remove the cable jacket to create a window cut per standard practice. Make sure the oscillation point (when present) is in the middle of the window cut.

Window cut is different for the different enclosure sizes. Please consult table below to select correct window cut dimensions:

	Window cut (cm)	Window cut (feet)
B6	250 cm	8.2 feet
C6(H)	300 cm	9.8 feet

Clean the tubes/subunits, remove all grease. Select the strength member and continue with a sub-section of section 9.3 depending the strength member type present in the cable.

9.2. Drop cable (stub cable)

Remove the cable jacket per standard practice over a length of 150 cm (4.9 feet).

	Strip length (cm)	Strip length (feet)
All	150 cm	4.9 feet

Clean the tubes/subunits, remove all grease. Select the strength member and continue with a sub-section of section 9.3 depending on the cable diameter and strength member type present in the cable.

9.3. Install CTU on cable

Measure the cable to select the correct CTU and/or the cable retention metal band. The diameter measure tape of the instruction can be used. Cut out and wrap around the cable.

Note: In the printed instruction, the diameter measure tape is in mm.

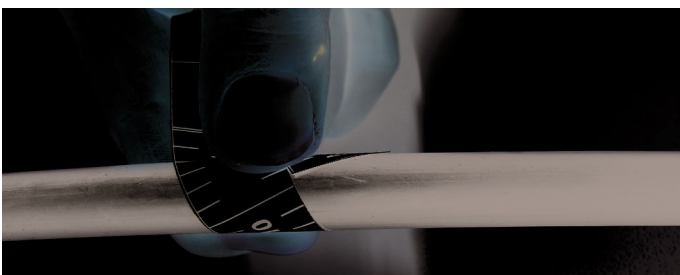

To select the correct cable retention metal band, the dimension measured should be between the two dimensions indicated on the metal band. For example, if the measured diameter is 15.5mm. Select 13-16 band.

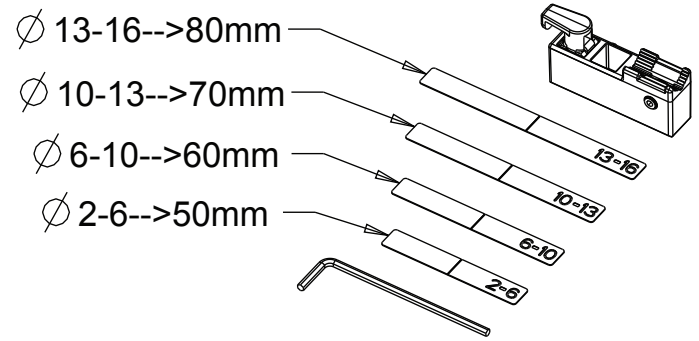

Depending on cable size and type of strength member, select one of the following sub sections to terminate the strength member.

	Cable diameter range
CTU-L	5-16 mm (0.2"-0.63")
CTU-S	2-6 mm (0.08"-0.24")

9.3.1. CTU-L - central strength member

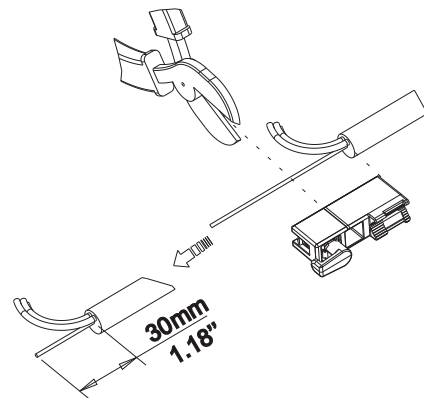

9.3.1.1. Cut the strength member to a length of 30mm (1.18"). To mark this distance, the line on the side of the CTU can be used. Hold the cable jacket flush with the bottom of the CTU and mark the strength member at the height of the line.

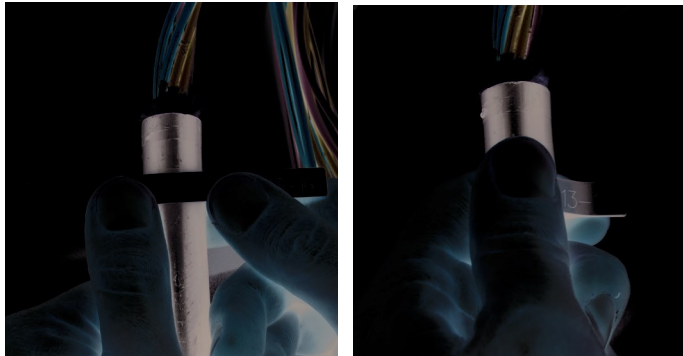
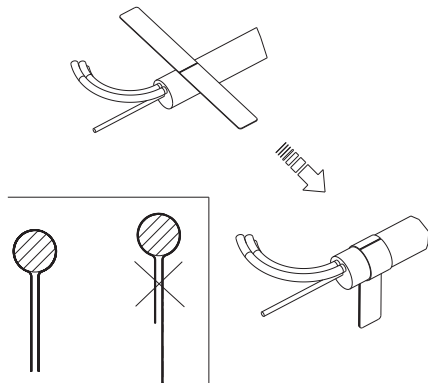

9.3.1.2. Bend the selected metal band around the cable while maintaining the centerlines (centerline of the metal band on the center of the cable). Make sure both ends of the metal band have equal lengths.

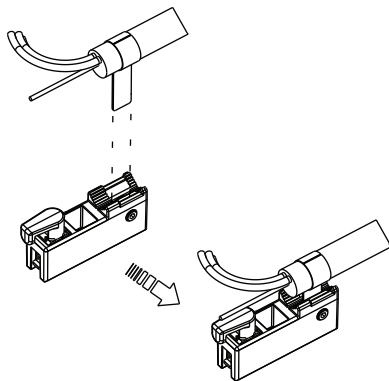

9.3.1.3. Insert the wrapped metal band in the CTU slot.

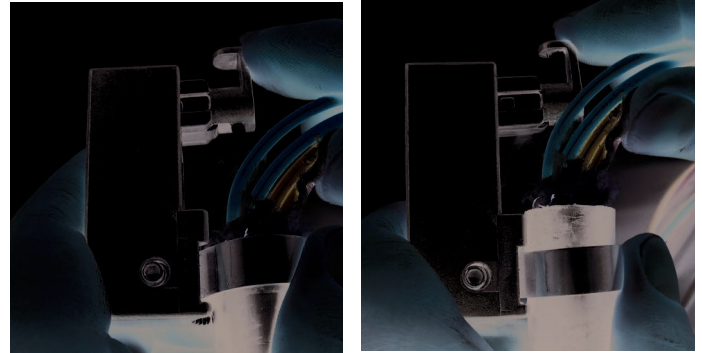
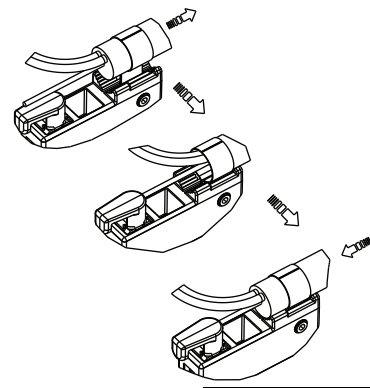

9.3.1.4. Insert the strength member in the strength member holder. First pull the cable slightly back (making sure the jacket doesn't pass the metal band), then move the strength member holder forward and then push the cable upwards again until the central strength member butts against the strength member holder's top surface. **Note:** some strength members may need to be trimmed in width to fit properly.

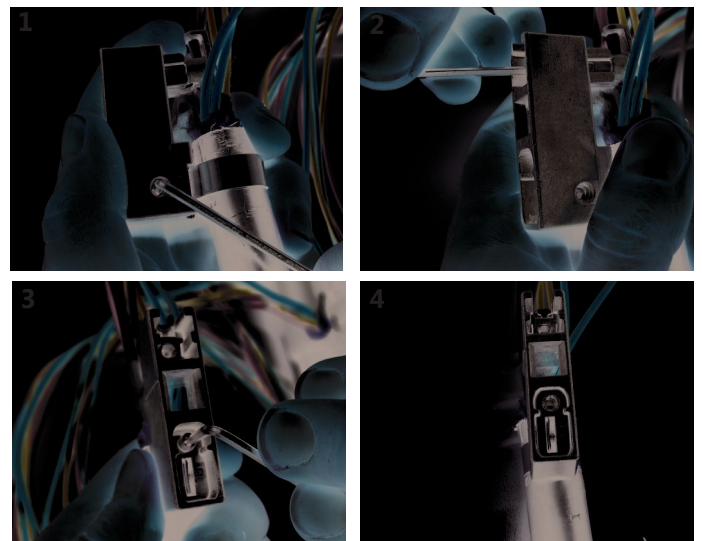
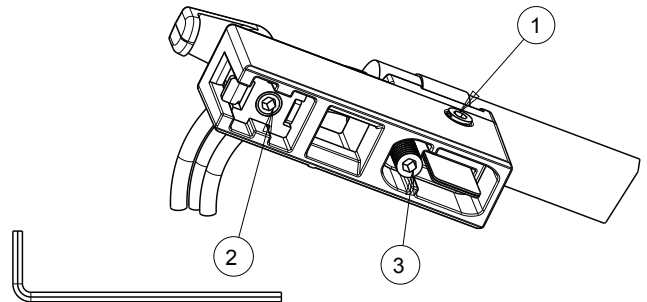

9.3.1.5. Tighten the screws with the Allen key included. **First** tighten the screw on the side to secure the metal band to the CTU. The cable is left unsecured at this point. **Second** tighten the screw to secure the strength member. **Third** tighten the screw to secure the cable jacket. The cable is now fully secured to the CTU.

9.3.2. CTU-L - dual strength member

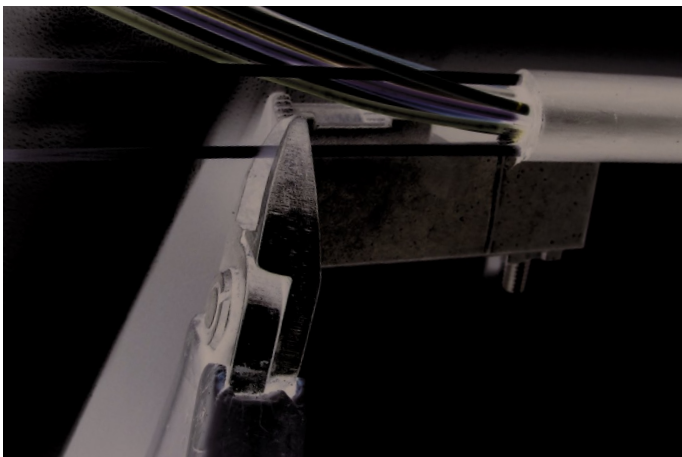

9.3.2.1. Cut one of the two strength members to a length of 30mm (1.18"). To mark this distance, the line on the side of the CTU can be used.

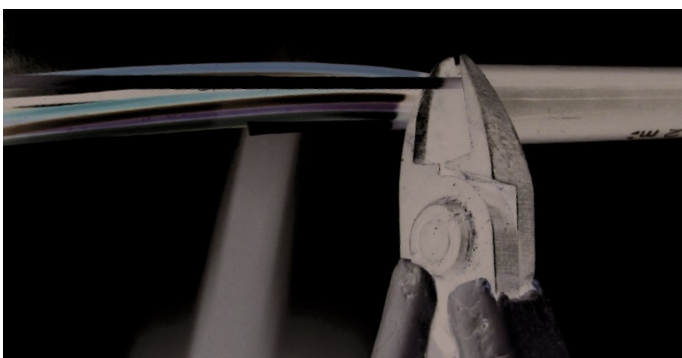

9.3.2.2. Remove the other strength member completely (cut it flush with the cable jacket).



9.3.2.3. Proceed with steps 9.3.1.2 until 9.3.1.5 to secure the cable jacket and the strength member to the CTU. Position the cable such that the remaining strength member is closest to the CTU.

9.3.3. CTU-L - aramid yarn

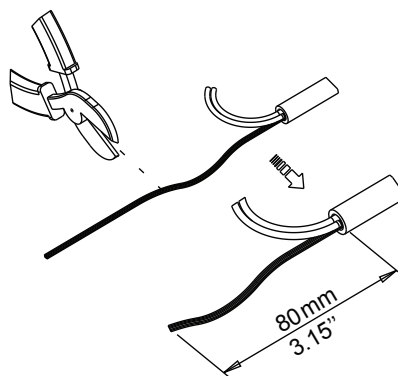

9.3.3.1. Cut the aramid yarn to a length of 80mm (3.15").

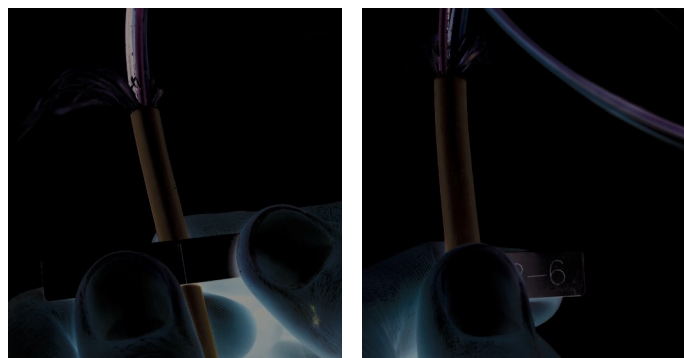
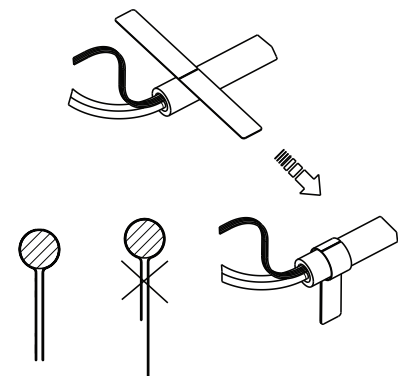

9.3.3.2. Bend the selected metal band around the cable while maintaining the centerlines (centerline of the metal band on the center of the cable). Make sure both ends of the metal band have equal lengths.

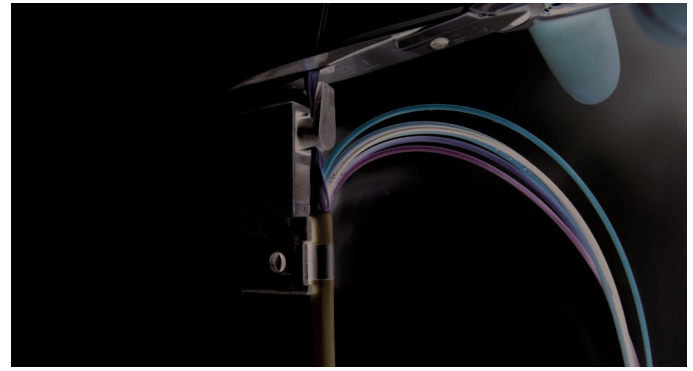
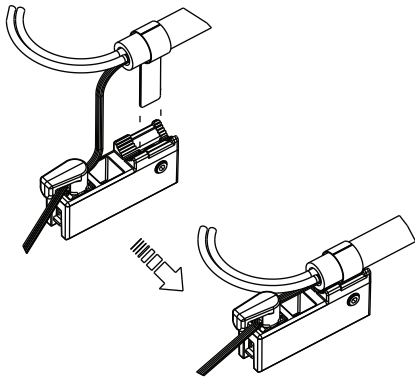

9.3.3.6. Cut the excessive aramid yarn as shown.

9.3.4. CTU-S - aramid yarn

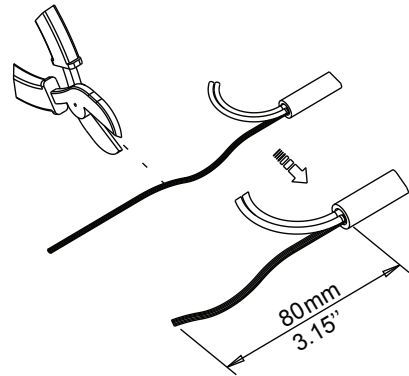

9.3.4.1. Cut the aramid yarn to a length of 80mm (3.15").

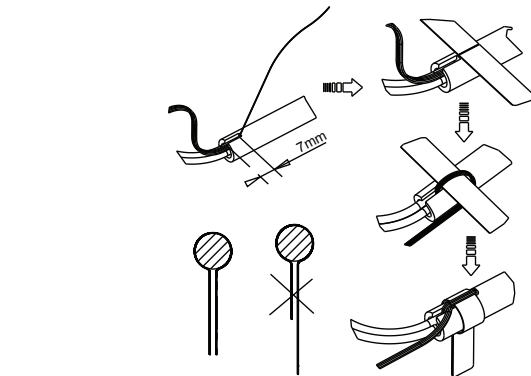

9.3.4.2. Make a slit of 7mm (0.27") in the jacket by pulling on a part of the aramid yarn. Position the metal band on the cable maintaining the centerlines and wrap the aramid around the band. Bend the band around the cable making sure both ends have equal lengths.

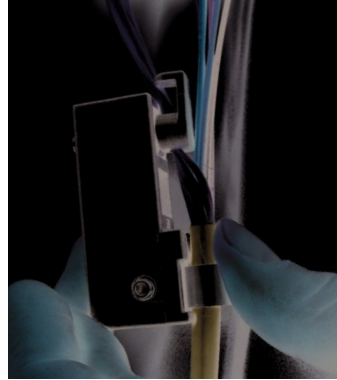

9.3.3.3. Insert the wrapped metal band in the CTU slot. Guide the aramid yarn through the strength member holder.

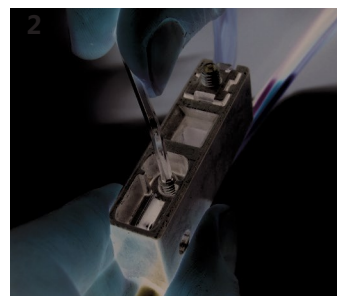
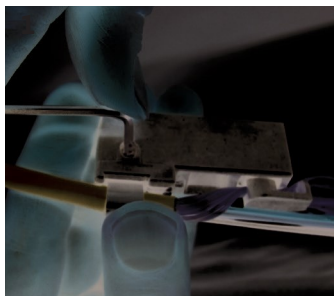
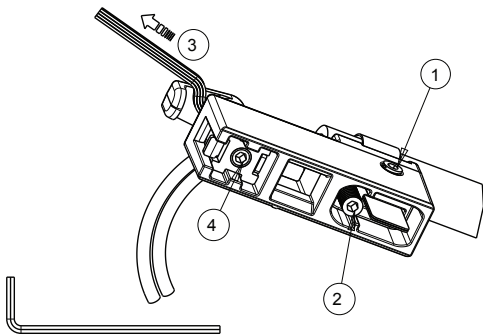

9.3.3.4. Secure the jacket of the cable to the CTU by first tightening the screw on the side and then tightening the screw at the back side of the CTU.

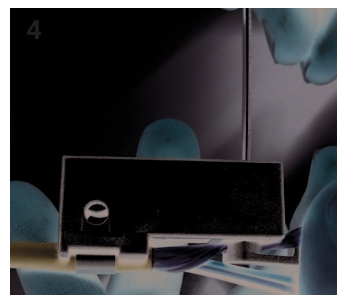

9.3.3.5. Pull on the aramid yarn and secure it in the strength member holder by tightening the screw of the back-side of the CTU.

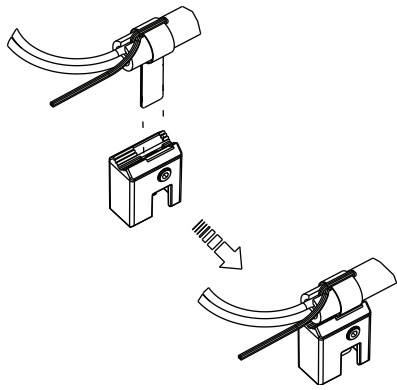

9.3.4.3. Insert the wrapped metal band in the CTU slot.

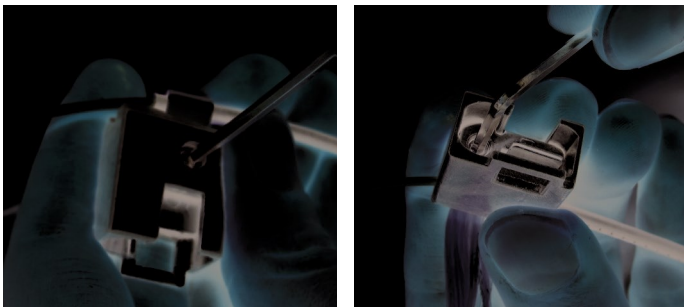
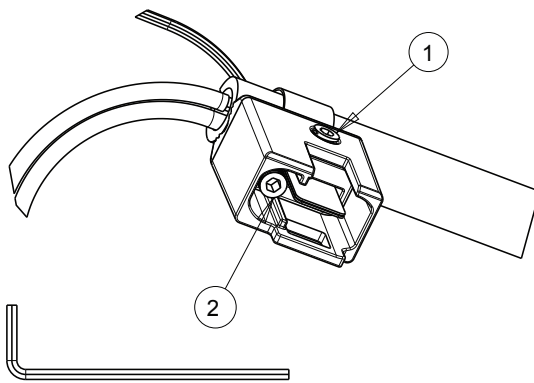

9.3.4.4. Secure the jacket of the cable to the CTU by first tightening the screw on the side and then tightening the screw at the back side of the CTU.



9.3.4.5. Cut the excessive aramid yarn as shown.

10. Install gel seal segments

10.1. Install side seal segments

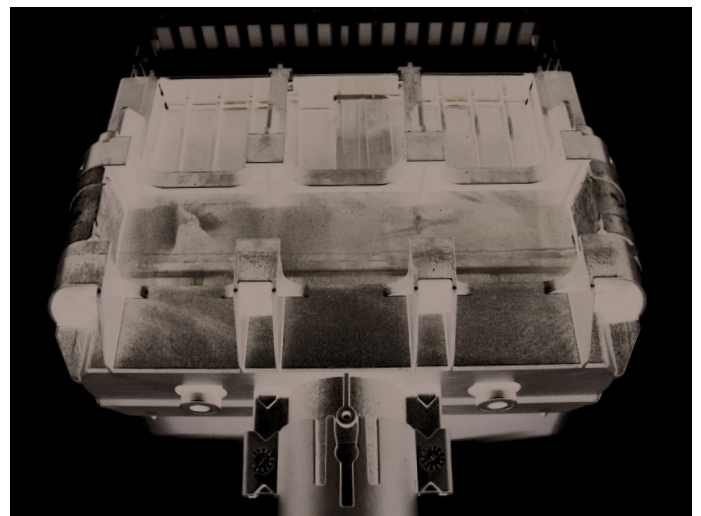
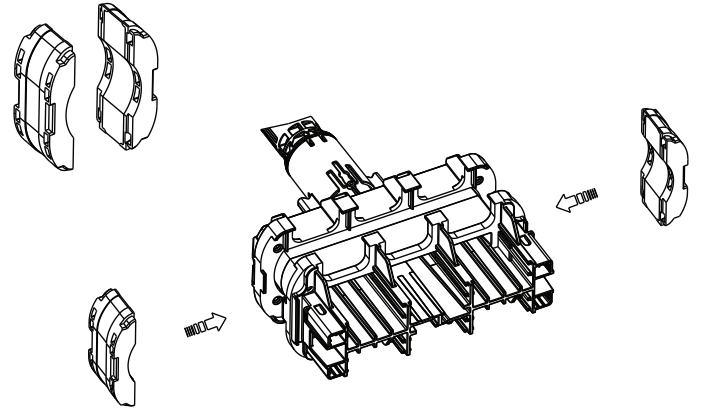

Remove the two side seal segments from the packaging and install them in the 2 side slots of the cable seal area. The gel can be squeezed slightly together to fit within the protrusions that will keep the side seal segments in place.

10.2. Install SKG for CTU-L

Select the SKG (seal kit gel) corresponding to the cable diameter used. The cable diameter range of the kit is stamped on the gel seals in the kit.

Keep in mind to install the selected seal kit in the slot of the cable seal area where the cable must be positioned.

When loop storage is required, the **feeder cable should be installed in the middle position at the back side** of the closure, install the selected kit for the feeder cable in the middle position at the back side.

Kit content of a SKG for CTU-L is shown on page 6.

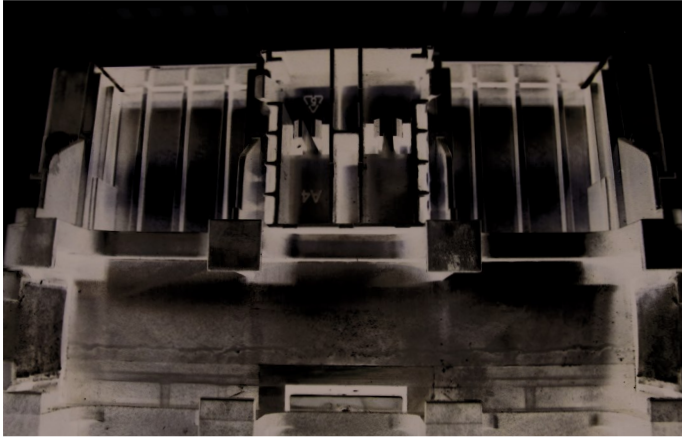

10.2.1 Position the CTU-holder in the correct slot of the CTU-holder area with the snap features at the top side. Note the orientation of the holder. Push CTU-holder into place.



10.2.2 Install one seal segment below the CTU-holder in the gel seal area.

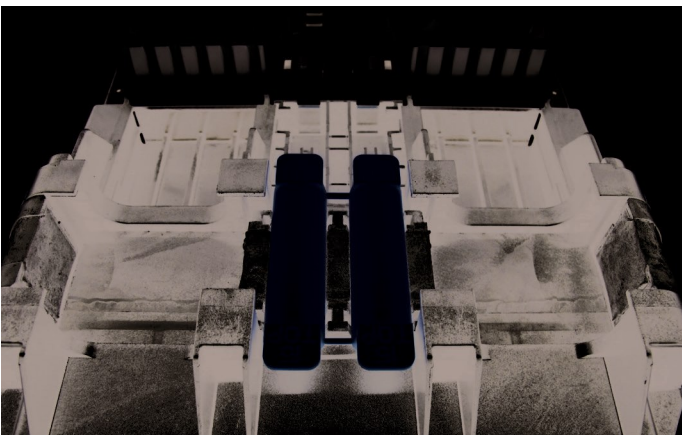

10.2.3 Install the dummy plugs in the unused positions of the gel port.

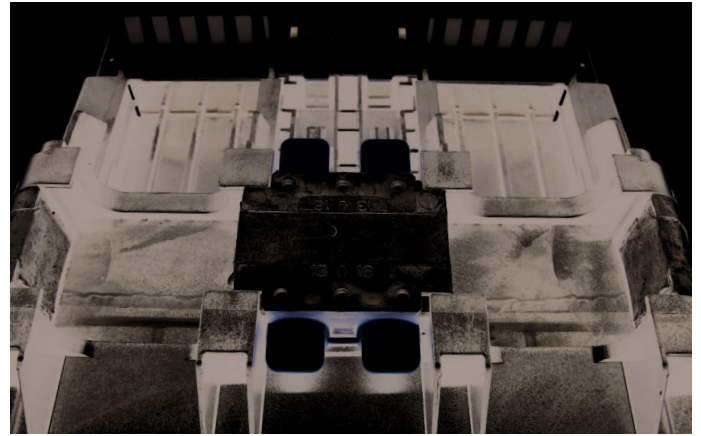

10.2.4 Install the second gel seal segment on top of the dummy plugs. Make sure the corners of the gel seal segment are properly inserted under the protrusions of the gel seal area.

10.3. Install SKG for CTU-S

Select the SKG (seal kit gel) corresponding to the cable diameter used. The cable diameter range of the kit is stamped on the gel seals in the kit.

Keep in mind to install the selected kit in the slot of the cable seal area where the cable must be positioned.

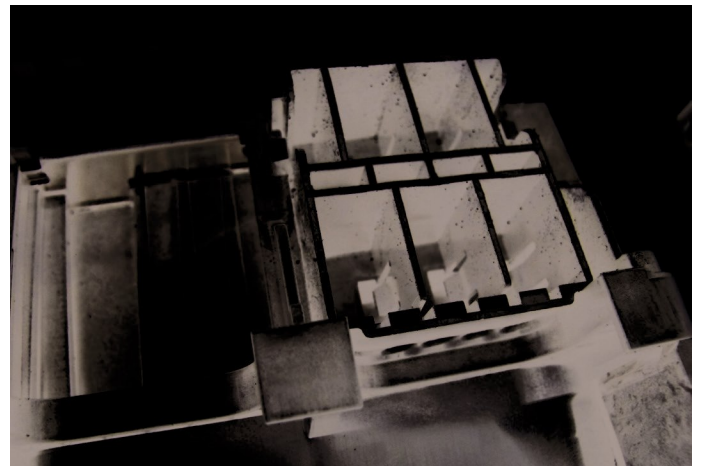

10.3.1 Position the CTU-holder in the correct slot of the CTU-holder area with the snap features at the top side. Note the orientation of the holder. Push the CTU-holder into place.

10.3.2 Install one seal segment below the CTU-holder in the gel seal area as shown in step 10.2.2.

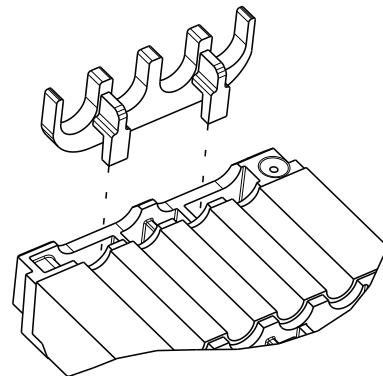

10.3.3 Install the cable guide in the slots below the seal segment.

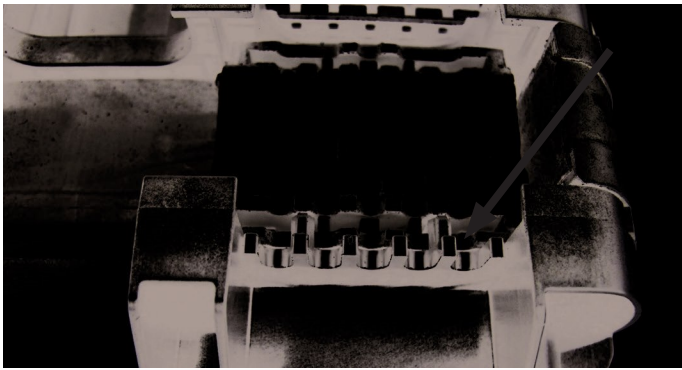

10.3.4 Cable guide installed.

10.3.5 Install the dummy plugs in the unused positions of the gel port as shown in step 10.2.3

10.3.6 Install the second gel seal segment on top of the dummy plugs. Make sure the corners of the gel seal segment are properly inserted under the protrusions of the gel seal area as shown in step 10.2.4

10.4. Install dummy SKG

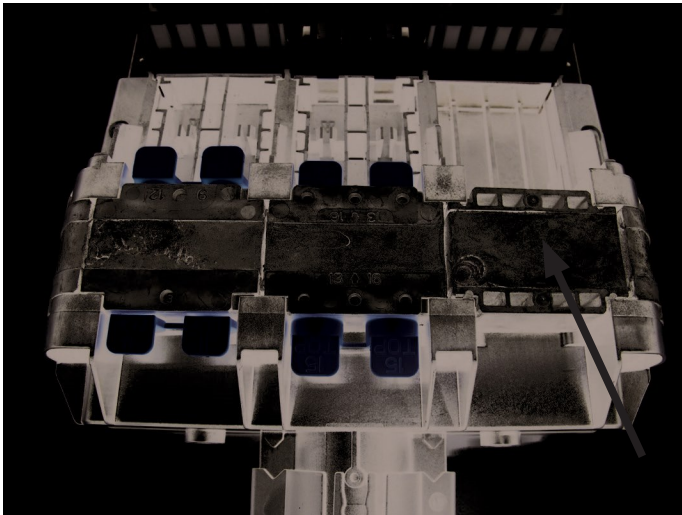

10.4.1 The dummy seal segment is only one part, no CTU holder should be installed. Squeeze the seal slightly together and install it under the protrusions (hooks) of the gel seal area.

Make sure all slots (3 on the back side and 3 on the front side of the enclosure) in the gel seal area are filled with one of the gel seal kits before proceeding.

11. Install looped feeder cable

11.1. Secure cable to enclosure

CTU's should already be installed on the both jacket ends of looped cable (see chapter 9).

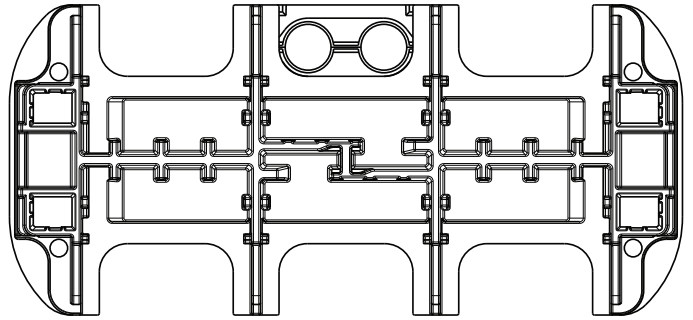

Looped cable should be installed in the middle position at the back side of the enclosure.

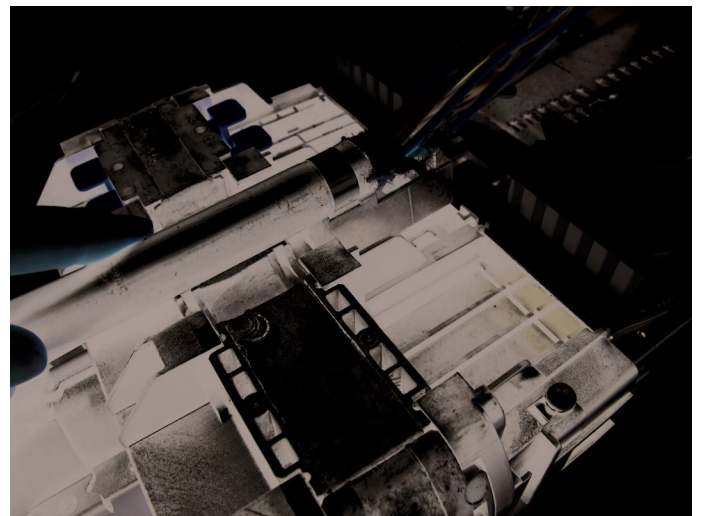

11.1.1 Remove the top gel seal segment and the dummy plugs. Click the both CTU's in the plastic CTU holder as shown.

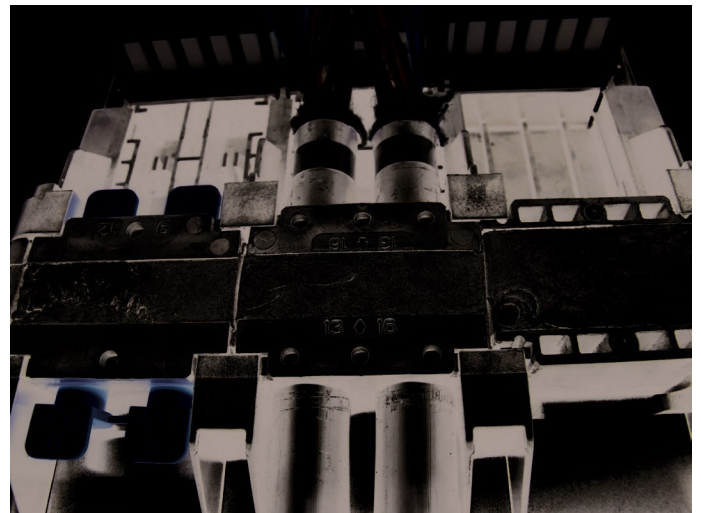

11.1.2 If there are unused positions in the gel seal segment, place a dummy plug in these positions. Place the second gel seal segment on top of the cables. Make sure the corners of the gel seal segment are properly inserted under the protrusions of the gel seal area.

11.2. Store loop

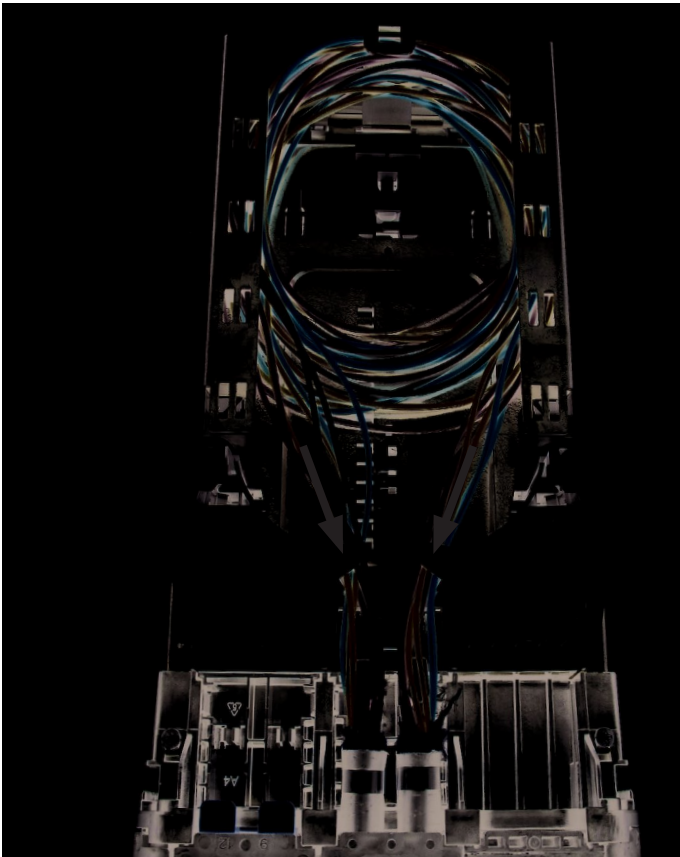

11.2.1 Loop the uncut tubes/subunits and store them within the dedicated area under the metal brackets. Cable ties can be used to secure the tubes/subunits to the metal bracket. Make sure all tubes/subunits are properly positioned under the two plastic hooks at the entrance of the loop storage area.

11.3. Tube/subunit holder

11.3.1 Select the tubes/subunit with the fibers to be spliced. The grooves in the tube/subunit holder area are designed for **tubes/subunits with a maximum Ø of 2.4mm (0.095")**.

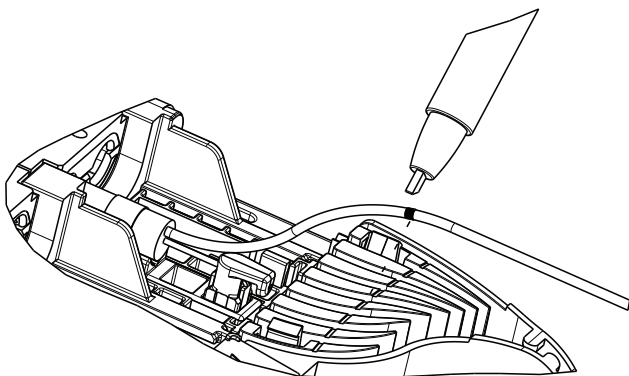

11.3.2 Remove the protection cover(s) of the tube/subunit holder area.

11.3.3 Position the tube/subunit on top of the groove and mark the tube/subunit at the point indicated with the lines. **Note:** the lines on the tube/subunit holder area are on a different location for the two grooves on the inside of the tube/subunit holder area as indicated in the next picture.



11.3.4 Example shows looped tube/subunit with marks at both sides. The tube/subunit can be shaved between these two marks.

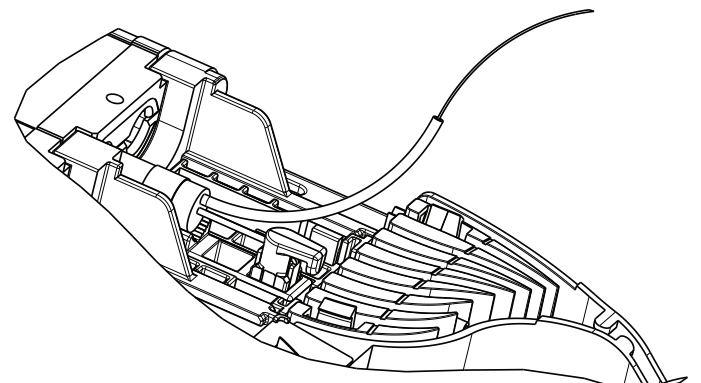
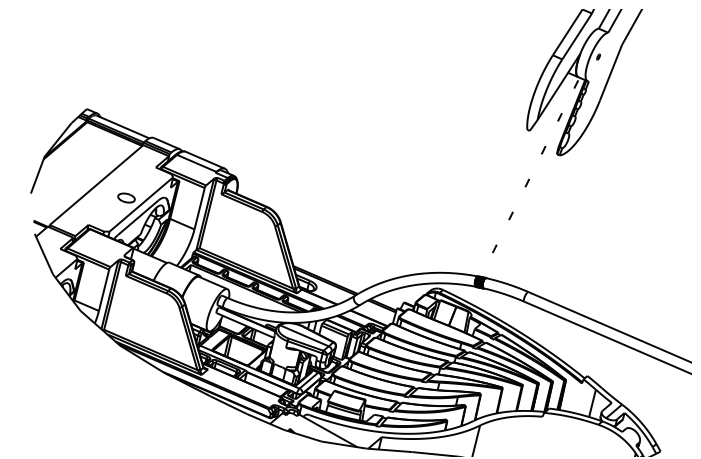

11.3.5 Strip the tube/subunit between or until the mark(s).

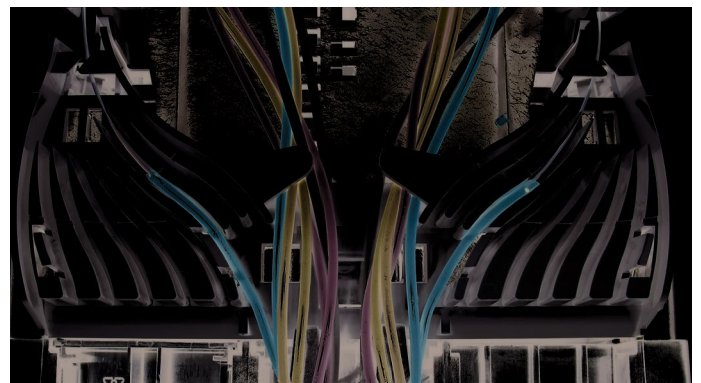

11.3.6 Insert the tube/subunits in the grooves of the tube/subunit holder area.

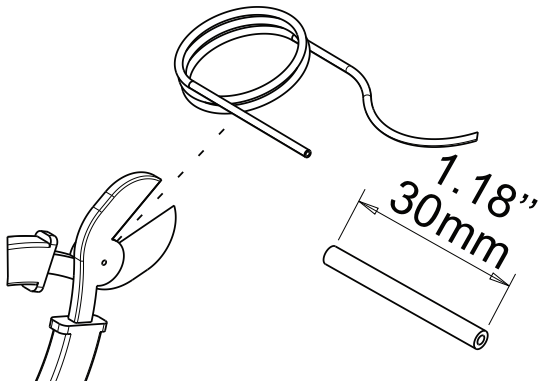

11.3.7 Cut a piece of the orange tubing of 30mm (1.18”).



11.3.11 Position the plastic cover with the openings over the snap features and push until it snaps.



11.3.8 Press the piece of orange tubing in the groove on top of the tube/subunit.
Note: place the end of the orange tube/subunit at the start of the groove. This makes it easier to remove the orange tubing.



11.3.12 Route the fibers to the front side (side of the splice trays) by guiding the fibers under the 2 hooks and then guiding them in the slit at the sides of the enclosure.

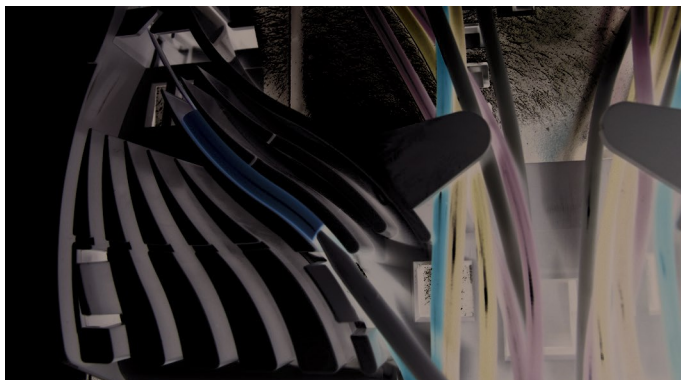

11.3.9 The orange tubing can be removed with a fiber guidance pin. The orange tubing need to be removed, if another tube/subunit need to be placed in the same groove.

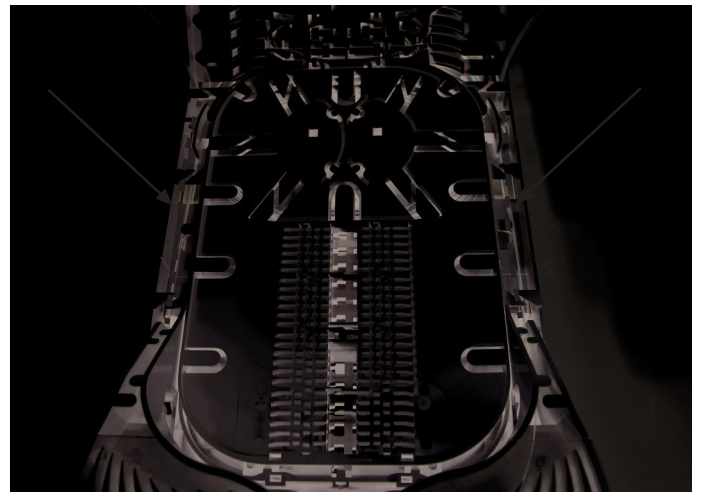

11.3.13 Route the fibers to the selected tray. See chapter 13 for detailed instructions concerning fiber routing.

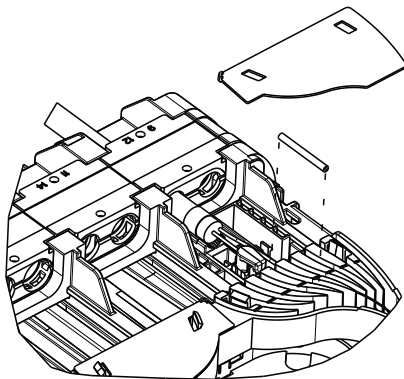

11.3.10 Re-install the protection cover over the tube/subunit holder area.

12. Install drop cable

Drop cables can be installed in all positions at the front side or in the positions in the two seal segments left and right at the back side.

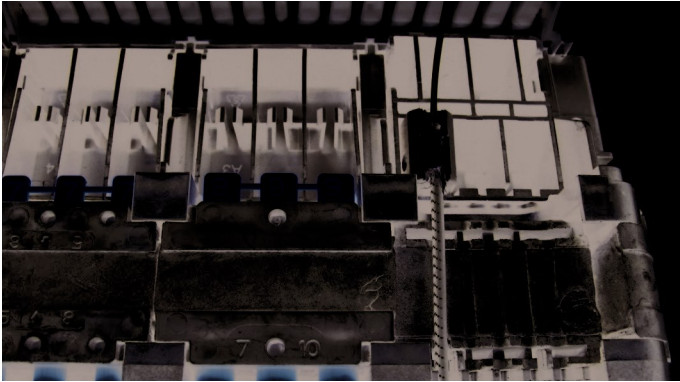

12.3.1 Remove the top gel seal segment and the dummy plugs. Click the CTU in the plastic CTU holder as shown.

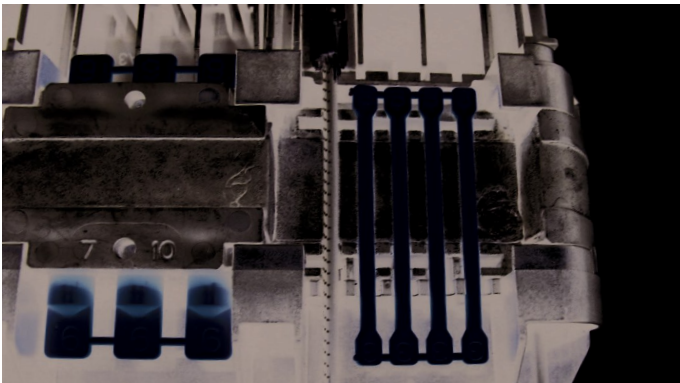

12.3.2 If there are unused positions in the gel seal segment, place a dummy plug in these positions (4 in example above).

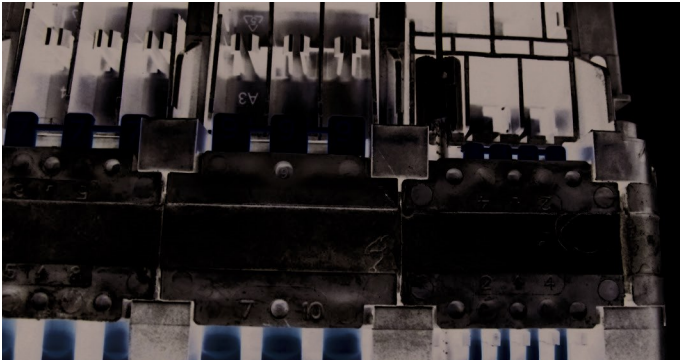

12.3.3 Place the second gel seal segment on top of the cables. Make sure the corners of the gel seal segment are properly inserted under the protrusions of the gel seal area.



12.3.4 Position the tube/subunit on top of the groove and mark the tube/subunit at the point indicated with the lines. The grooves in the tube/subunit holder area are designed for **tube/subunits with a maximum Ø of 2.4mm.**



12.3.5 Strip the tube/subunit up to the mark.



12.3.6 Insert the tube/subunit in the grooves of the tube/subunit holder area. Cut a piece of the orange tubing of 30mm (1.18"). Press the piece of orange tubing in the groove on top of the tube/subunit. Note: place the end of the orange tube/subunit at the start of the groove. This makes it easier to remove the orange tubing.



12.3.7 Re-install the protection cover over the tube/subunit holder area. Position the plastic cover with the openings over the snap features and push until it snaps.

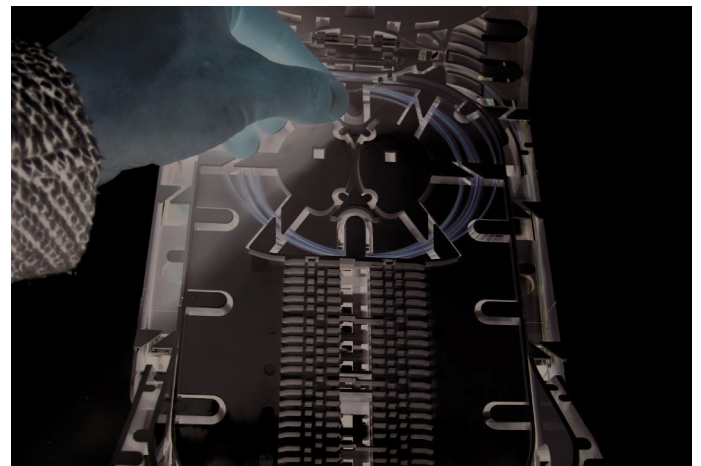

12.3.8 Route the fibers to the selected tray. See chapter 13 for detailed instructions concerning fiber routing.

13. Splice application

13.1. Routing to the tray

Note: only 250µ fiber continue from the tube/subunit holder area to the tray (with exception of the patch trays). Only 250µm fiber is allowed in the fiber guidance area.

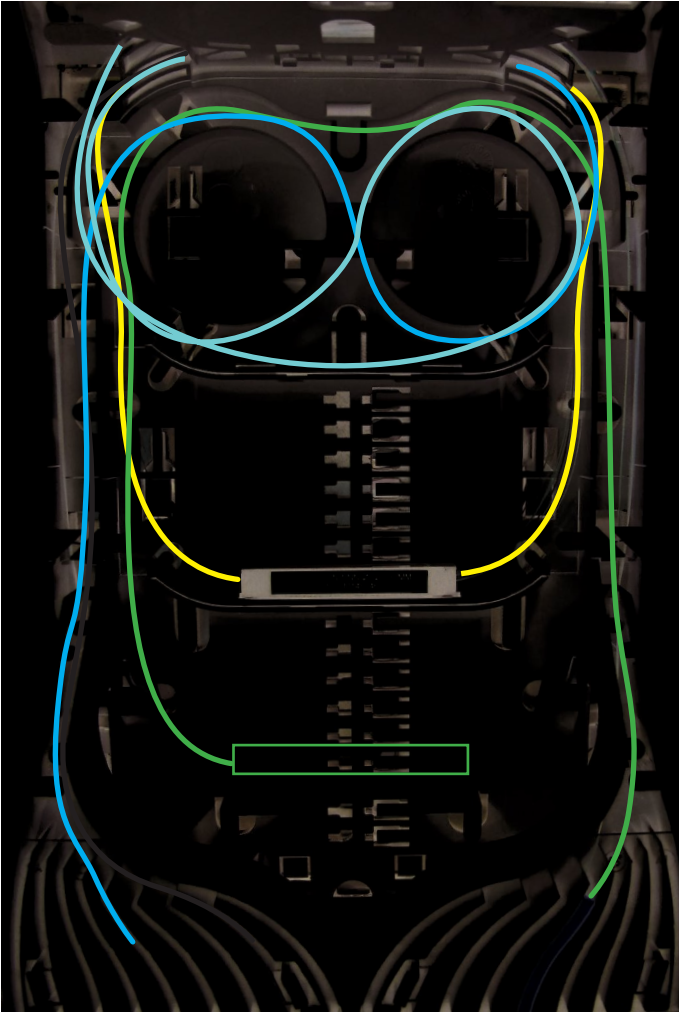

- Black fiber routing from drop port at the front side directly to the tray.
- Blue fiber routing from drop port at the front side to the other side of the tray passing around the drums of the FAS under the trays.
- Green fiber routing from drop port at the front side to an additional splice holder stored in the POC area.
- Yellow fiber routing from the splitter (input and output) to the tray.
- Teal inter-tray jump. Routing of a fiber from one tray to another entering the tray at the same side.

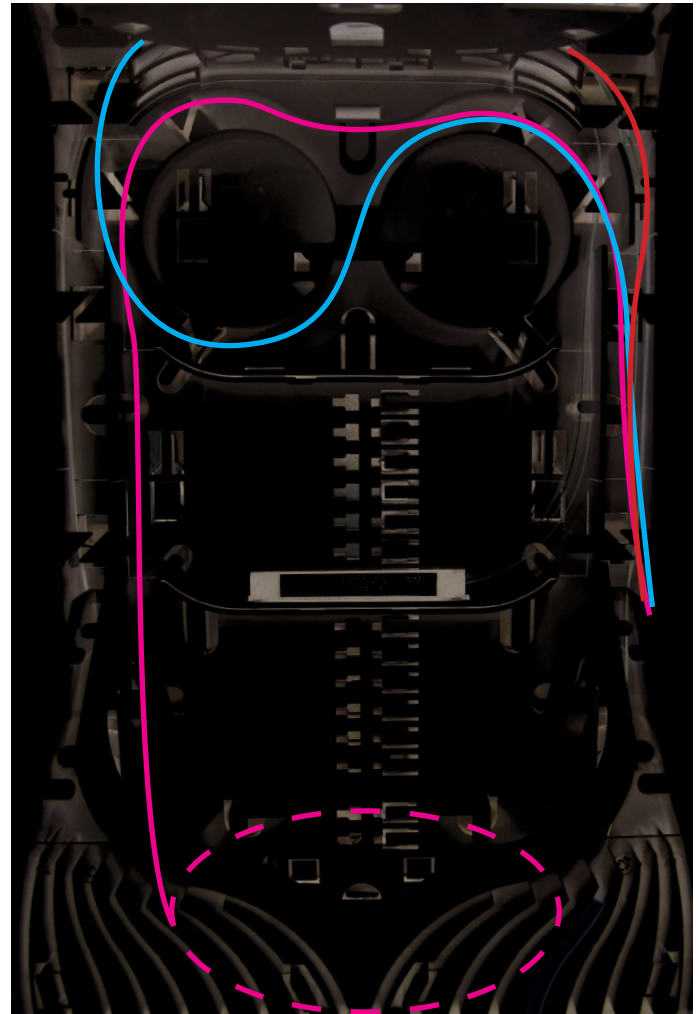

- Red fiber routing from drop port at the back side or from feeder port directly to the tray.
- Blue fiber routing from drop port at the back side or from feeder port to the other side of the tray passing around the drums of the FAS under the tray.
- Fuchsia routing from feeder port to dark fiber storage at the front side.
Note: if there are no POC installed in the pocket behind the tube/subunit holders, dark fiber can be stored in this area.



Picture above shows the slot used to route the fiber from the back side to the front side.

13.2. Routing on the tray

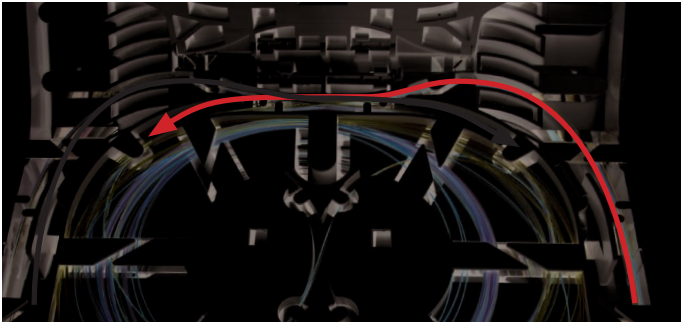

Select the groove on the tower that routes the fiber to the tray. The fiber continues in the groove of the tray. Fibers entering the tray from the opposite sides cross each others in the middle of the tray (called FAS).

Fibers can be stored around the island present on each tray. (See dotted black lines on image below.) On some trays, there are pass through grooves available between and under the splice protector holders. These can be used to store more or longer length of fiber.

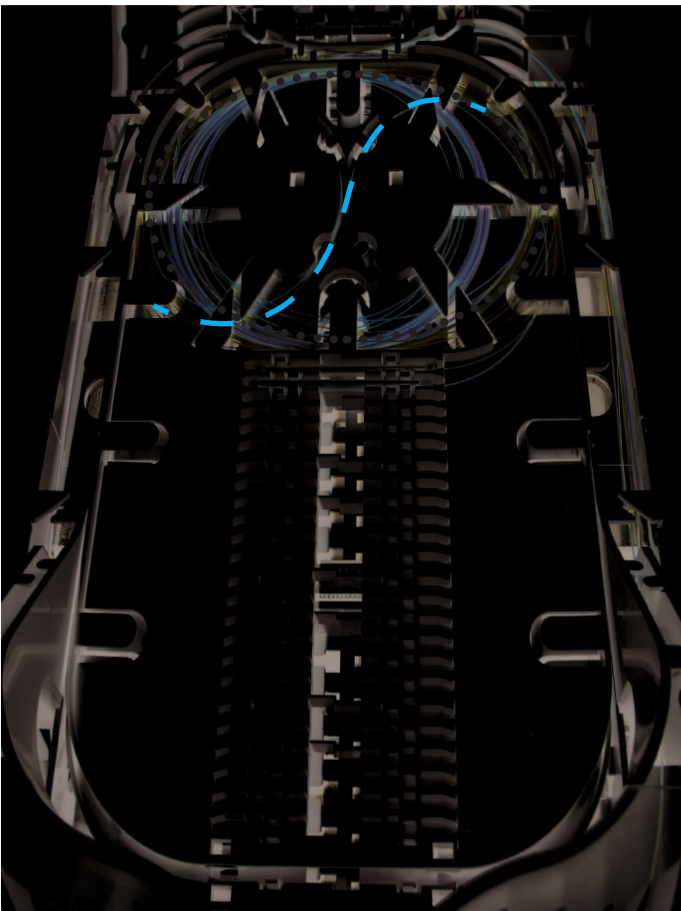

Splice per standard practice and store the splice protector in the splice protector holder.

Note: the FAS on the tray can be used to make crossings on the tray; if the fibers need to be spliced enters the tray from the same side, one fiber can make a S-shaped U-turn on the tray using the openings in the island (see blue dotted line on the image above).

Note: When storing (over length) fibers, observe the following general rules:
 1. The fibers may not be routed too tight around the island.
 2. Make sure all fibers are properly positioned under the lips.

14. Patch application

There are 2 sizes of patch trays available:

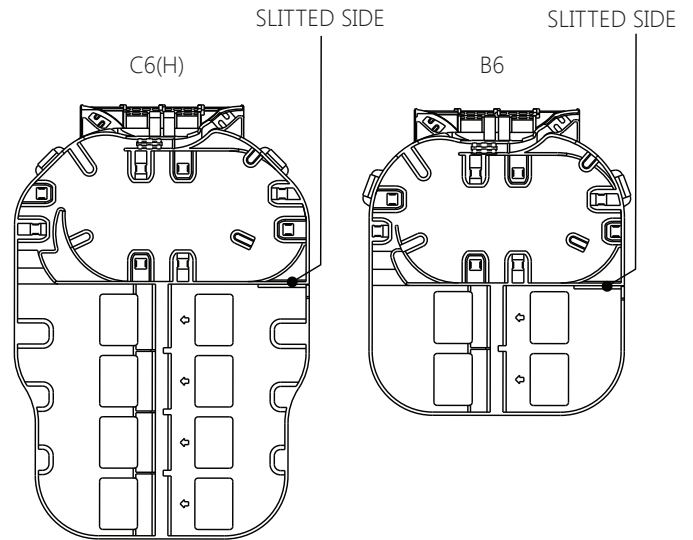

Information about the amount and the type of adapters compatible with this tray can be retrieved in the eCatalog.

Both trays have at one side of the tray a slit to route the patch cord from the front side of the tray to the back side.

If present, the two or three splice trays must be installed in the bottom positions of the tower. On top of these trays, the patch trays are installed. Patch trays should be installed above the lips of the fiber guidance channel therefore the patch trays can only be installed starting from a certain position on the tower:

- position 4 for the C6 enclosure and;
- position 3 for B6/C6H enclosure.

Between two patch trays one or two hinge positions must remain unused; see table below:

	splice trays installed under patch trays	hinge position unused between 2 patch trays
B6/ C6H	maximum 2	2
C6	maximum 3	1



14.1. Push the tray hinge of the patch tray into the snap features on the tower. Start with position 4 for the C6H enclosure and with position 3 for the C6H and B6 enclosures.

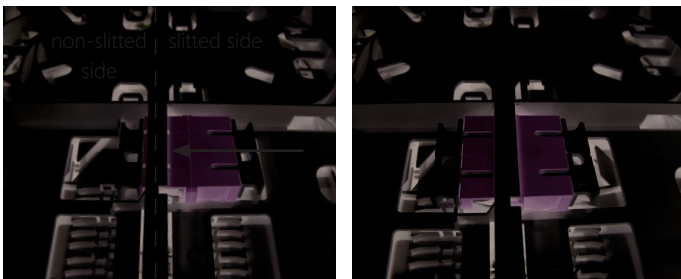

14.2. Slide the adapter in the tray. Slide it from the slitted side of the tray to the non-slitted side. Verify the proper orientation of the adapter: U-slots facing upwards and metal springs facing towards the non-slitted side of the tray.

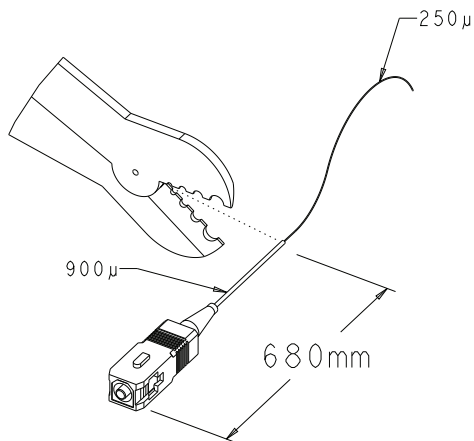

14.3. Measure a length of 680mm (26.77") of the connector point and make a mark. Strip the tube/subunit up to this mark.

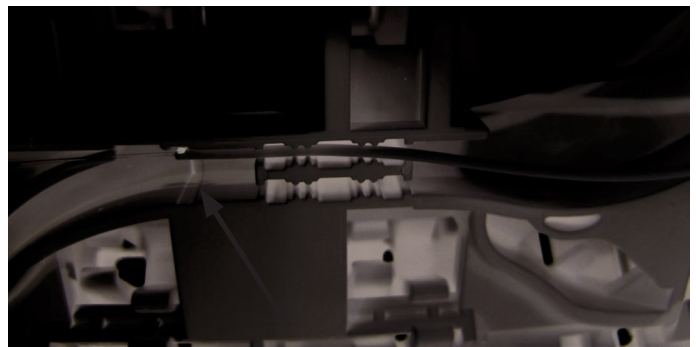

14.6. Insert the end of the pigtail in the notch. The jacket end of the pigtail is positioned on the groove indicated with an arrow.

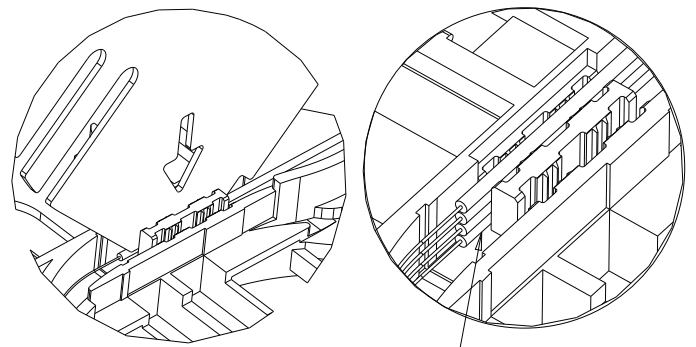

14.7. Slide the pigtail in the notch to the bottom position using the side of the transparent cover (indicated with an arrow).

Maximum 4 pigtails can be stacked in one notch. 8 pigtails can be secured at the entrance of one pocket.



14.4. Remove the dust cap of both, the adapter and the connector, and connect the patch cord into the adapter. Make sure the rib on the connector of the patch cord is facing upwards (it should slide in the slots of the adapter). Clean connectors if contamination is suspect or high insertion loss is discovered.

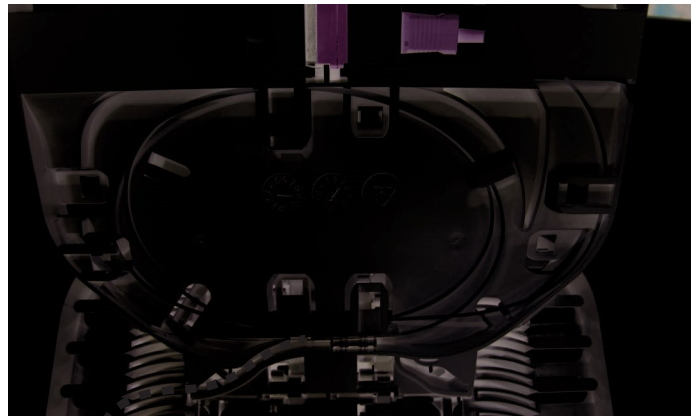

14.8. Store over length of the pigtail under the lips in the pocket at the back side of the tray. Route the fiber in the groove to the fiber guidance channel.

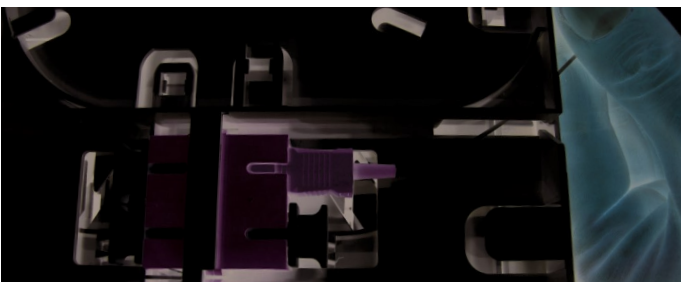

14.5. Route the pigtail of all connectors installed at the slitted side of the tray to the pocket at the back side of the tray through the slit (as shown in the picture).

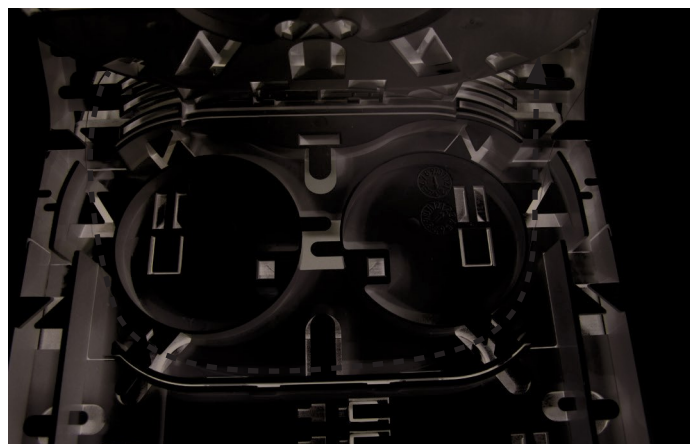

14.9. Route the fiber to the FAS under the trays and upwards again towards the splice tray.

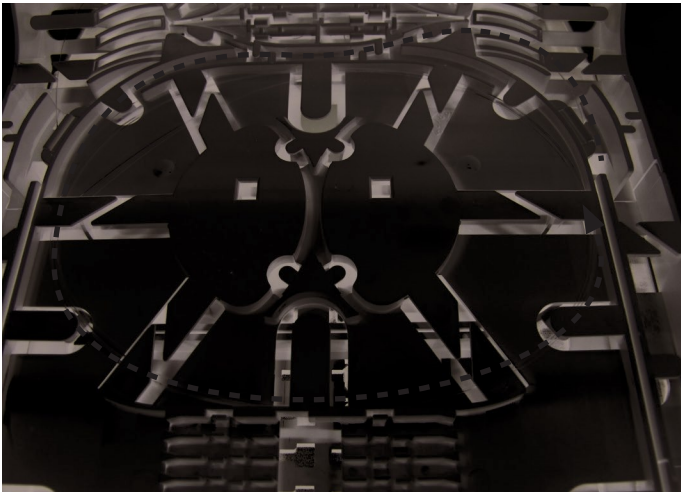

14.10. Route the fiber to the splice tray where the fiber will be spliced to a fiber or a drop or a feeder cable.

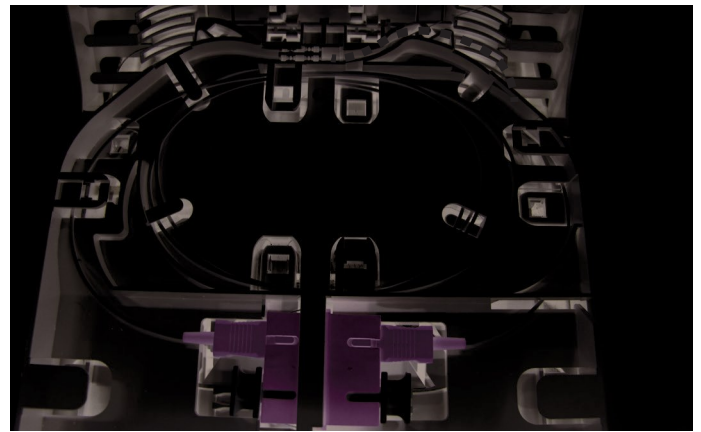

14.15. Store over length of the pigtail under the lips in the pocket above the adapters. Route the fiber in the groove to the fiber guidance channel.

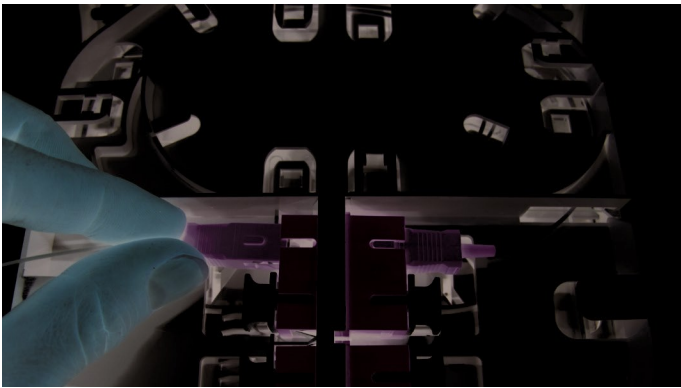

14.11. Remove the dust cap of both, the adapter of the opposite side and the connector, and connect the patch cord into the adapter. Make sure the rib on the connector of the patch cord is facing upwards (it should slide in the slots of the adapter). Clean connectors if contamination is suspect or high insertion loss is discovered.

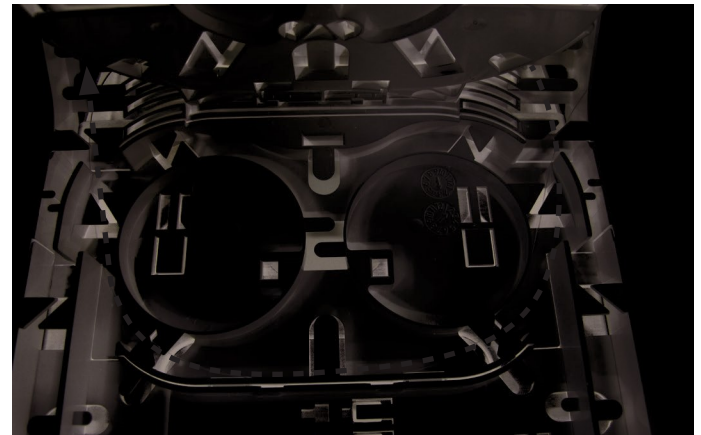

14.16. Route the fiber to the FAS under the trays and upwards again towards the splice tray where the fiber will be spliced to a fiber of a drop or a feeder cable.

14.12. Route the pigtail of all connectors installed at the non-slitted side of the tray to the pocket above the adapters.



14.13. Insert the end of the pigtail in the notch. The jacket end of the pigtail is positioned on the groove indicated with an arrow.

14.14. Slide the pigtail in the notch to the bottom position using the side of the transparent cover (indicated with an arrow). (See left figure in step 14.7.) Maximum 4 pigtails can be stacked in one notch. 8 pigtails can be secured at the entrance of one pocket. (See right figure in step 14.7.)

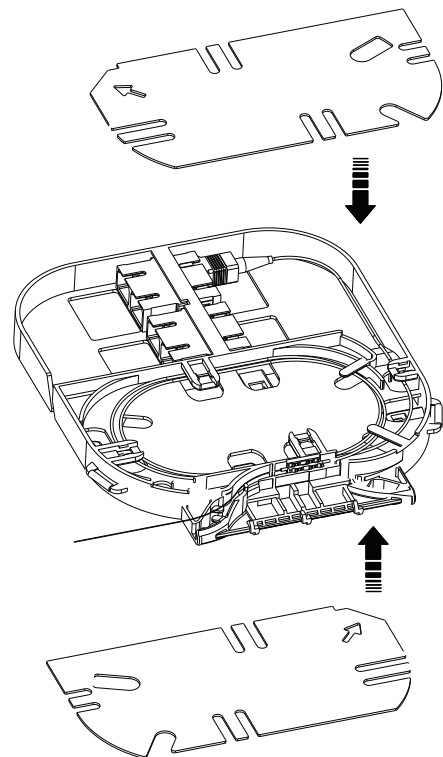

14.17. Install the transparent covers on the pockets at the front side and at the back side of the tray.

15. Close and seal enclosure

15.1. Make sure the seal segments are properly installed in all the 6 seal slots.

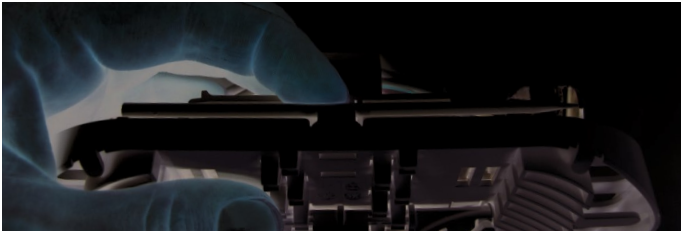

15.2. Put the fiber dressing tool and the wedge into its place at the top of the backside of the organizer.

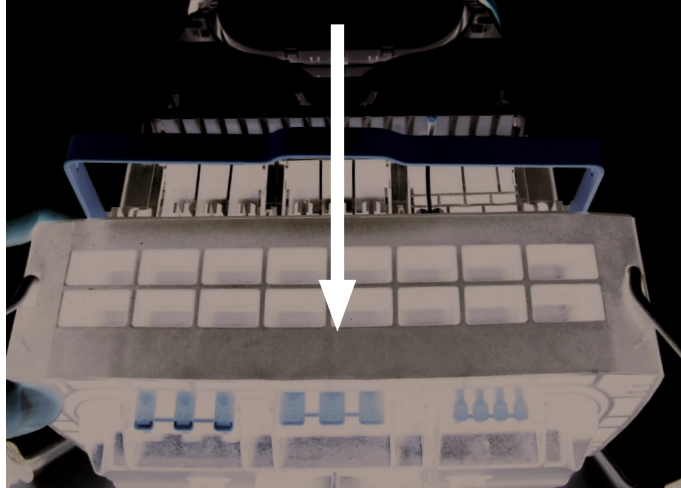

15.3. Slide the base over the organizer and put it in its correct position over the gel seals.

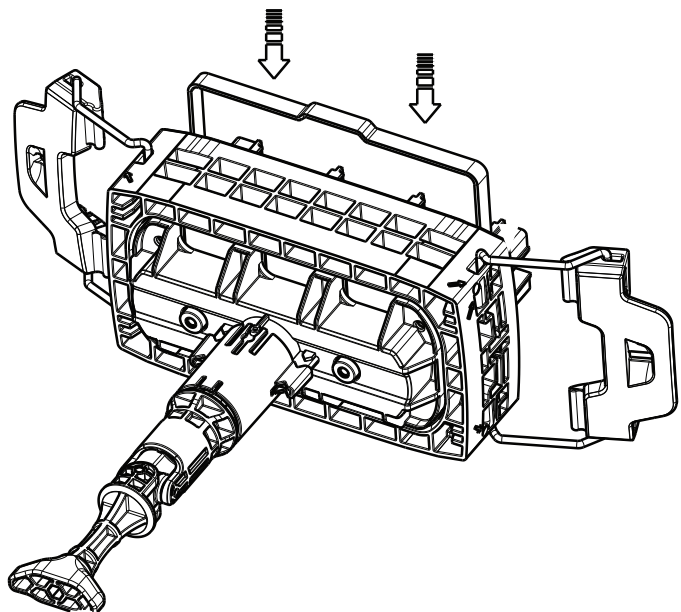

15.4. Lock the base by pushing the yellow bracket downwards into the slots.

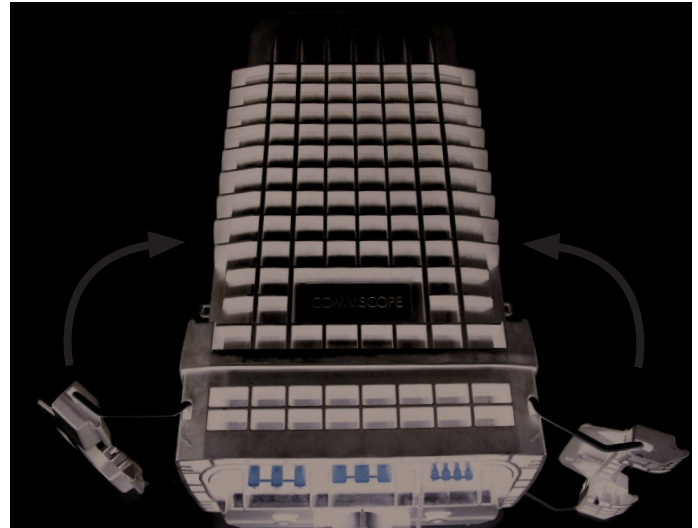

15.5. Position the dome over the organizer.

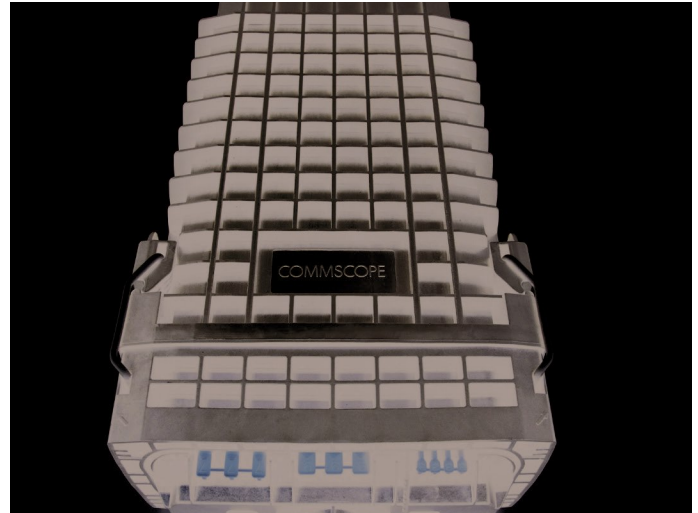

15.6. Close the latches.

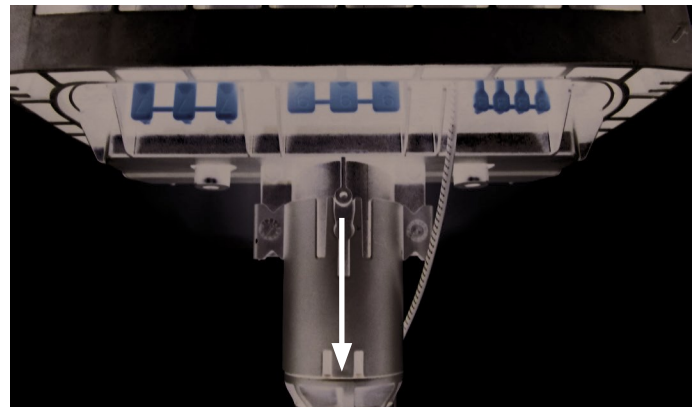
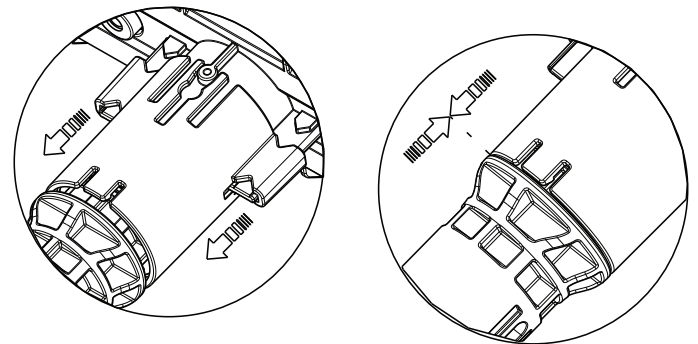

15.7. Before engaging the seal mechanism, make sure the flange hits the bottom surface.

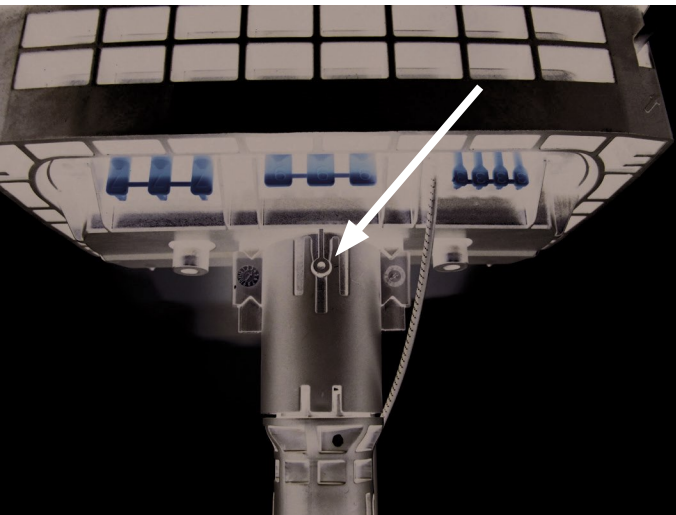
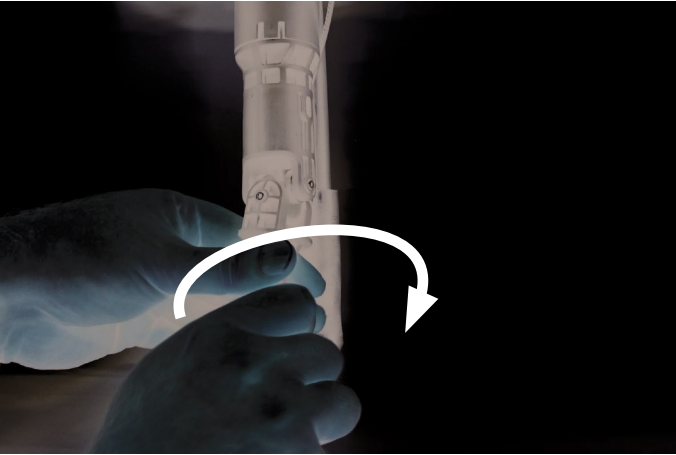
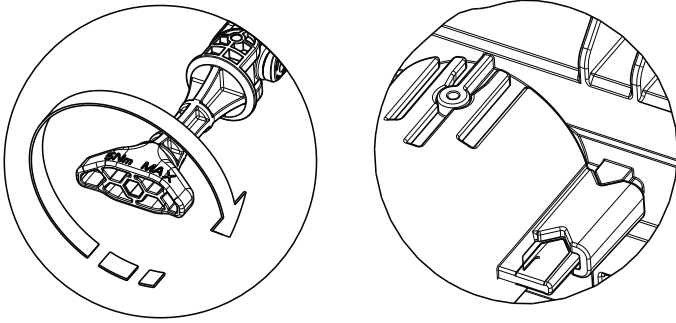

15.8. Activate the seal mechanism by turning the handle (trigger) clockwise. The flange will move upwards until the two snaps in the middle jump over the little round feature.

Note: Maximum force applied to turn handle is 5Nm

16. External cable fixation

An external cable fixation bracket can be installed on the enclosure to secure the cables with a cable tie before entering the enclosure. This reliefs stress on the sealing.

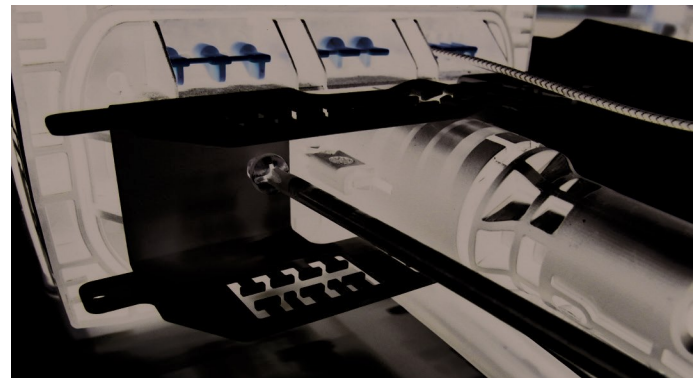
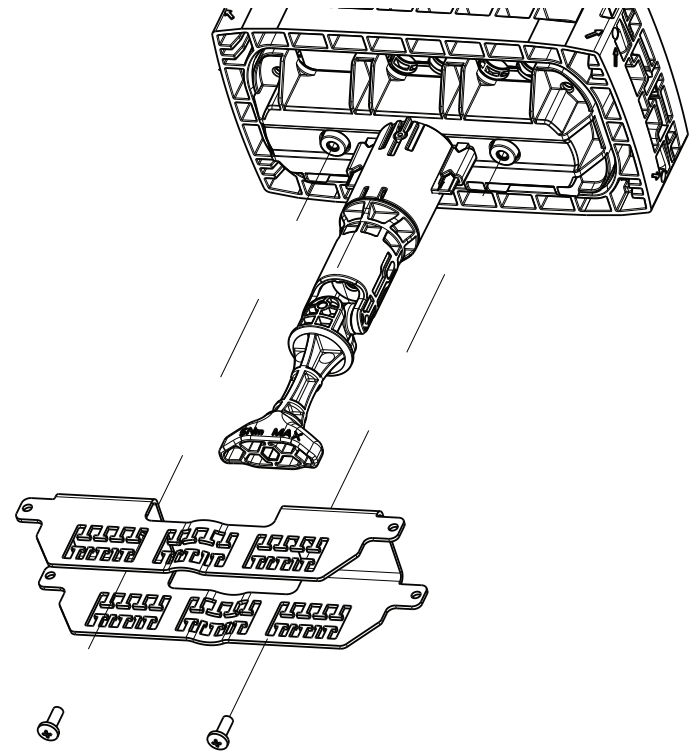

16.1. Mount the cable fixation bracket on the enclosure. The two screws should be secured in the holes in the two protrusions on the bottom of the enclosure with a Phillips screw driver.

16.2. Cut a piece of foam. Wrap it around the cable on the place where the cable will be secured to a T-shape of the bracket.

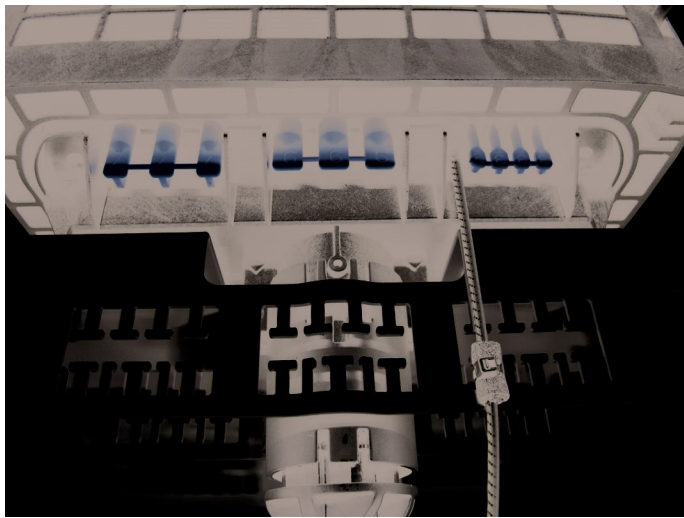

16.3. Secure the cable to the bracket. Make sure the cable makes a straight line. To define the T-shape corresponding the cable's position, consult table and image below:

yellow	1-out	middle T-shape bottom row
red	2-out	two middle T-shapes top row
green	3-out	middle, and outer T-shapes bottom row
light blue	4-out	all T-shapes top row
dark blue	5-out	all T-shapes bottom row

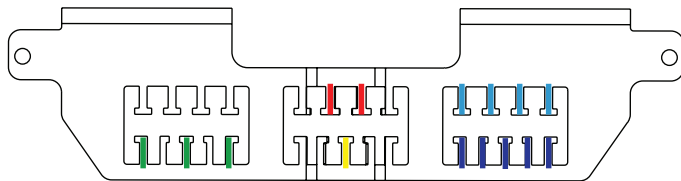

17. Mounting bracket

17.1. Dimensions

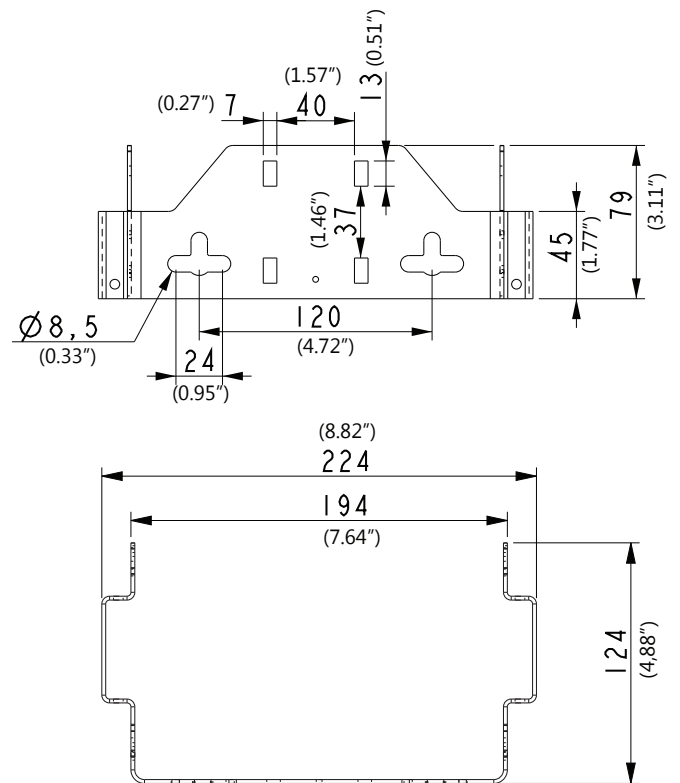

17.2. Mount the enclosure

17.2.1. Wall mounting

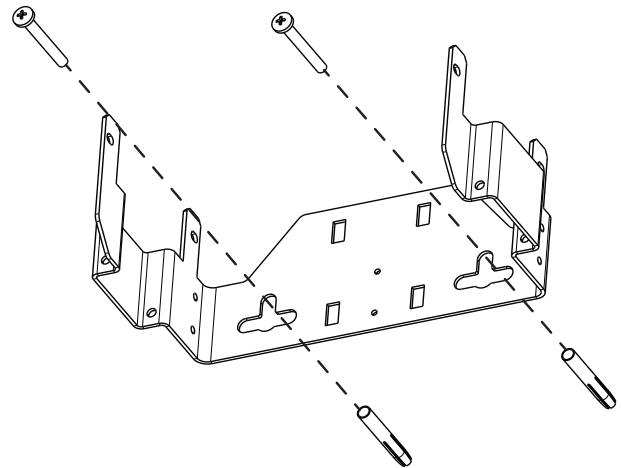

Position the bracket on the wall and mark the position of the screws. Drill 2 holes of M8 and insert the plugs. Tighten the screws with a socket wrench.

17.2.2. Pole mounting

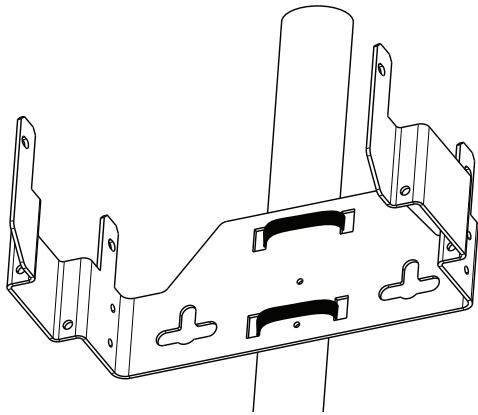

The 4 square holes in the middle of the bracket can be used to mount the bracket to a pole with metal straps.

17.2.3. Mount enclosure on the bracket

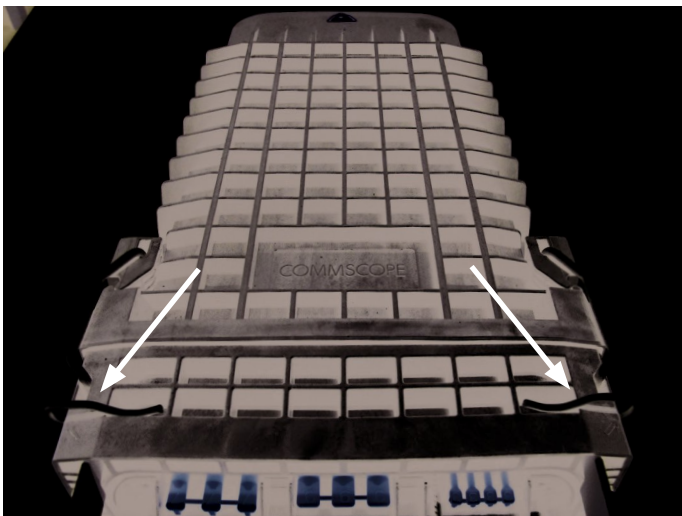

Slide the enclosure over the 4 lugs. The base of the enclosure grips on the 4 lugs.

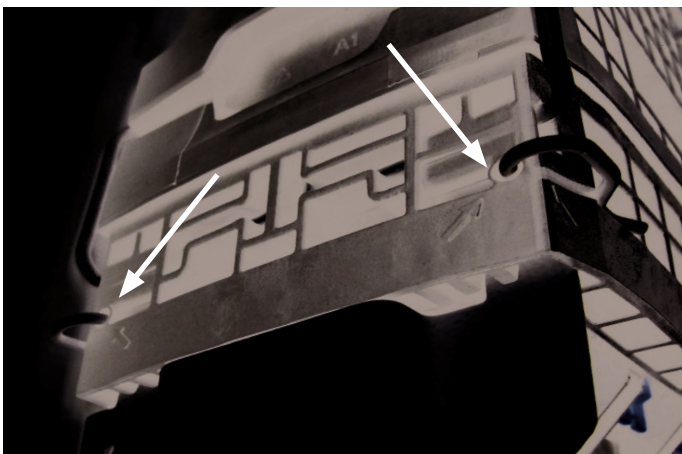

Lock the base onto the lugs of the bracket with the 4 split pins (2 at the front side and 2 at the back side). The holes are indicated with arrows on the base in picture above.

17.3. Open enclosure when using the bracket

17.3.1. Remove dome only

If the mounting bracket is locked to the base, only the dome can be removed. Open the latches and lift off the dome. If the dome is removed, the organizer is accessible and the management of the fibers to and on the tray can be performed.

17.3.2. Remove dome and base

If the optional cable fixation bracket is installed, the mounting bracket can be locked to the cable fixation bracket. The split pins should be removed from the base and must be inserted through the holes at the bottom.



The sealing mechanism must be disengaged before the base can be removed from the seal area. See section 18 Re-entry. Picture below shows the mounting bracket secured to the cable fixation bracket and the dome and base removed. Cables can be added.

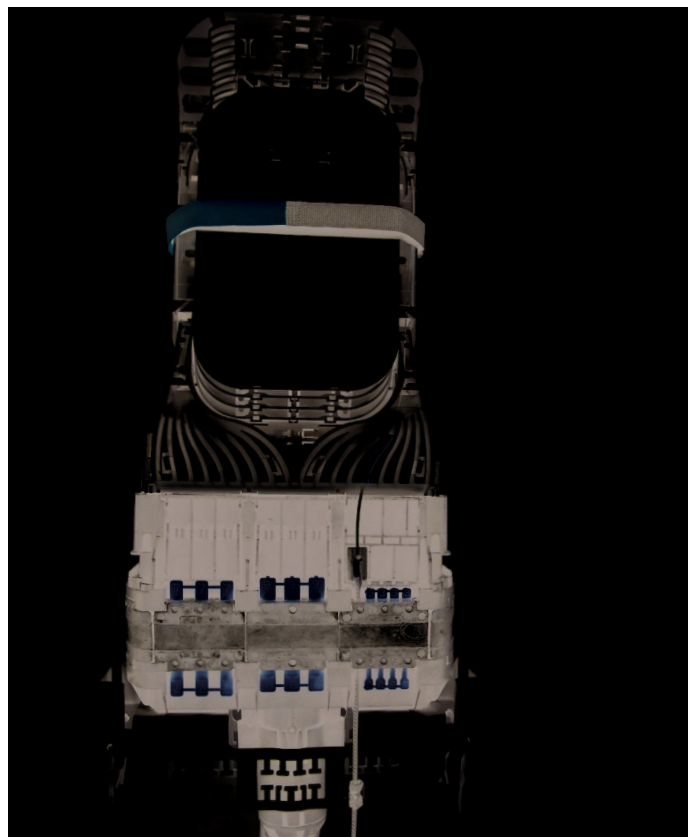

18. Re-entry

The enclosure is designed to permit cables to be added after the first installation. It is important to disengage the sealing mechanism before removing the base.



18.1. Turn the handle counter-clockwise. The flange can move downwards.

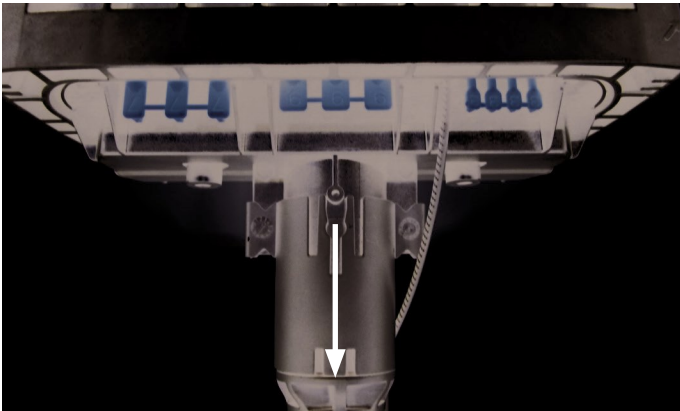

18.2. The sealing mechanism is fully disengaged, when the little round feature is positioned above the snap features.

18.3. Now the organizer can be accessed in 2 ways:

Slide the entire organizer downwards. This can only be done when the cable provides enough slack to make this movement.

Remove the dome and the base as explained in section 8.1.

19. Trade-marks

All trademarks identified by ® or ™ are registered trademarks or trademarks, respectively, of CommScope, Inc. This document is for planning purposes only and is not intended to modify or supplement any specifications or warranties relating to CommScope products or services. CommScope is committed to the highest standards of business integrity and environmental sustainability, with a number of CommScope's facilities across the globe certified in accordance with international standards, including ISO 9001, TL 9000, and ISO 14001.

Further information regarding CommScope's commitment can be found at www.commscope.com/About-Us/Corporate-Responsibility-and-Sustainability.

20. Contact information

Visit our website or contact your local CommScope representative for more information.

For technical assistance, customer service, or to report any missing/damaged parts, visit us at: <http://www.commscope.com/SupportCenter>

This product may be covered by one or more U.S. patents or their foreign equivalents. For patents, see www.cs-pat.com.